

# **marantz®**

## **Model PS-17 User Guide**

---

AV Amplifier

## ENGLISH

### WARRANTY

For warranty information, contact your local Marantz distributor.

#### RETAIN YOUR PURCHASE RECEIPT

Your purchase receipt is your permanent record of a valuable purchase. It should be kept in a safe place to be referred to as necessary for insurance purposes or when corresponding with Marantz.

### IMPORTANT

When seeking warranty service, it is the responsibility of the consumer to establish proof and date of purchase. Your purchase receipt or invoice is adequate for such proof.

### FOR U.K. ONLY

This undertaking is in addition to a consumer's statutory rights and does not affect those rights in any way.

## FRANÇAIS

### GARANTIE

Pour des informations sur la garantie, contacter le distributeur local Marantz.

#### CONSERVER L'ATTESTATION D'ACHAT

L'attestation d'achat est la preuve permanente d'un achat de valeur. La conserver en lieu sûr pour s'y reporter aux fins d'obtention d'une couverture d'assurance ou dans le cadre de correspondances avec Marantz.

### IMPORTANT

Pour l'obtention d'un service couvert par la garantie, il incombe au client d'établir la preuve de l'achat et d'en corroborer la date. Le reçu ou la facture constituent des preuves suffisantes.

## DEUTSCH

### GARANTIE

Bei Garantiefragen wenden Sie sich bitte an Ihren Marantz-Händler.

#### HEBEN SIE IHRE QUITTING GUT AUF

Die Quittung dient Ihnen als bleibende Unterlage für Ihren wertvollen Einkauf. Das Aufbewahren der Quittung ist wichtig, da die darin enthaltenen Angaben für Versicherungszwecke oder bei Korrespondenz mit Marantz angeführt werden müssen.

### WICHTIG!

Bei Garantiefragen muß der Kunde eine Kaufunterlage mit Kaufdatum vorlegen. Ihren Quittung oder Rechnung ist als Unterlage ausreichend.

## NEDERLANDS

### GARANTIE

Voor inlichtingen omtrent garantie dient u zich tot uw plaatselijke Marantz.

#### UW KWITANTIE, KASSABON E.D. BEWAREN

Uw kwitantie, kassabon e.d. vormen uw bewijs van aankoop van een waardevol artikel en dienen op een veilige plaats bewaard te worden voor evt. verwijzing bijv. in verband met verzekering of bij correspondentie met Marantz.

### BELANGRIJK

Bij een evt. beroep op de garantie is het de verantwoordelijkheid van de consument een gedateerd bewijs van aankoop te tonen. Uw kassabon of factuur zijn voldoende bewijs.

## ITALIANO

### GARANZIA

L'apparecchio è coperto da una garanzia di buon funzionamento della durata di un anno, o del periodo previsto dalla legge, a partire dalla data di acquisto comprovata da un documento attestante il nominativo del Rivenditore e la data di vendita. La garanzia sarà prestata con la sostituzione o la riparazione gratuita delle parti difettose.

Non sono coperti da garanzia difetti derivanti da uso improprio, errata installazione, manutenzione effettuata da personale non autorizzato o, comunque, da circostanze che non possano riferirsi a difetti di funzionamento dell'apparecchio. Sono inoltre esclusi dalla garanzia gli interventi inerenti l'installazione e l'allacciamento agli impianti di alimentazione.

Gli apparecchi verranno riparati presso i nostri Centri di Assistenza Autorizzati. Le spese ed i rischi di trasporto sono a carico del cliente. La casa costruttrice declina ogni responsabilità per danni diretti o indiretti provocati dalla inosservanza delle prescrizioni di installazione, uso e manutenzione dettagliate nel presente manuale o per guasti dovuti ad uso continuato a fini professionali.

## PORTUGUÊS

### GARANTIA

Para informações sobre a garantia, contactar o distribuidor Marantz local.

#### GUARDAR O RECIBO DE COMPRA

O recibo é o registo permanente da compra que fez. Deve ser guardado num local seguro, para ser apresentado em questões relacionadas com o seguro ou para quando tiver de contactar a Marantz.

### IMPORTANTE

Quando procurar assistência técnica ao abrigo da garantia, é da responsabilidade do consumidor estabelecer a prova e data de compra. O recibo é prova adequada.

## ESPAÑOL

### GARANTIA

Para obtener información acerca de la garantía póngase en contacto con su distribuidor Marantz.

#### GUARDE SU RECIBO DE COMPRA

Su recibo de compra es su prueba permanente de haber adquirido un aparato de valor. Este recibo deberá guardarlo en un lugar seguro y utilizarlo como referencia cuando tenga que hacer uso del seguro o se ponga en contacto con Marantz.

### IMPORTANTE

Cuando solicite el servicio otorgado por la garantía el usuario tiene la responsabilidad de demostrar cuándo efectuó la compra. En este caso, su recibo de compra será la prueba apropiada.

## SVENSKA

### GARANTI

För information om garantin, kontakta Marantz lokalagent.

#### SPAR KVITTOT

Kvittot är ett inköpsbevis på en värdefull vara. Det skall förvaras säkert och hänvisas till vid försäkringsfall eller vidkorrespondens med Marantz.

### VIKTIGT

Fö att garantin skall gälla är det kundens sak att framställa bevis och datum om köpet. Kvitto eller faktura är tillräckligt bevis för detta.

## DANSK

### GARANTI

Henvend dem til Deres MARANTZ-forhandler angående information om garantien.

#### GEM DERES KVITTERING

Deres købskvittering er Deres varige bevis på et dyrt køb. Den bør gemmes godt og anvendes som bevis, hvis De vil tegne en forsikring, eller hvis De kommunikerer med Marantz.

### VIKTIGT

Det påhviler forbrugeren at skaffe bevis for købet og købsdatoen, hvis han eller hun ønsker garantiservice. Deres købskvittering eller faktura er et fuldgældigt bevis herpå.

# CE MARKING

- English**  
The PS-17 is in conformity with the EMC directive and low-voltage directive.
- Français**  
Le PS-17 est conforme à la directive EMC et à la directive sur les basses tensions.
- Deutsch**  
Das Modell PS-17 entspricht den EMC-Richtlinien und den Richtlinien für Niederspannungsgeräte.
- Nederlands**  
De PS-17 voldoet aan de EMC eisen en de vereisten voor laag-voltage.
- Español**  
El PS-17 está de acuerdo con las normas EMC y las relacionadas con baja tensión.
- Italiano**  
Il PS-17 è conforme alle direttive CEE ed a quelle per i bassi voltaggi.
- Português**  
O PS-17 conforma com as diretrizes EMC e de baixa voltagem.
- Svenska**  
PS-17 är tillverkad i enlighet med EMC direktiven och direktiven för lågvoltsutrustning.
- Dansk**  
Model PS-17 er i overensstemmelse med EMC-direktivet og direktivet om lavspænding.

## English

To ventilate the unit, do not install the unit in a rack or bookshelf, and note the followings.

- Do not touch the top of the enclosure during operation.
- Do not block the openings in the enclosure during operation.
- Do not insert objects beneath the unit.
- Do not block the ventilation slots at the top of the unit.
- Do not place anything about 1 meter above the top panel.
- Make a space of about 0.2 meter around the unit.

## Français

Pour que l'appareil puisse être correctement ventilé, ne pas l'installer dans un meuble ou une bibliothèque et respecter ce qui suit.

- Ne pas toucher le dessus du coffret.
- Ne pas obstruer les ouïes de ventilation du coffret pendant le fonctionnement.
- Ne placer aucun objet sous l'appareil.
- Ne pas obstruer les ouïes de ventilation du panneau supérieur. Ne placer aucun objet à moins d'un mètre environ du panneau supérieur.
- Veiller à ce qu'aucun objet ne soit à moins de 0,2 mètre des côtés de l'appareil.

## Deutsch

Um eine einwandfreie Belüftung des Geräts zu gewährleisten, darf das Gerät nicht in einem Gestell oder Bücherregal aufgestellt werden; die folgenden Punkte sind besonders zu beachten:

- Während des Betriebs das Oberteil des Gehäuses nicht berühren.
- Während des Betriebs die Öffnungen im Gehäuse nicht blockieren.
- Keine Gegenstände in das Gerät einführen.
- Die Belüftungsschlitze an der Oberseite des Geräts dürfen nicht blockiert werden. Darauf achten, daß über dem Gerät ein Freiraum von mindestens 1 meter vorhanden ist.
- Auf allen Geräteseiten muß ein Zwischenraum von ungefähr 0,2 meter vorhanden sein.

## Nederlands

Installeer het toestel niet in een rek of boekenkast waar de ventilatie mogelijk wordt gehinderd. Let tevens op de volgende punten:

- Raak de bovenkant van het toestel niet aan als het in gebruik is.
- Blokkeer de openingen van het toestel niet als het in gebruik is.
- Plaats geen onderwerpen onder het toestel.
- Blokkeer de ventilatie-openingen aan de bovenkant van het toestel niet. Zorg dat er tenminste 1 meter vrije ruimte boven het toestel is.
- Zorg dat er 0,2 meter vrije ruimte rond het toestel is.

## Español

Para ventilar la unidad no la instale en una estantería ni estante para libros, y tenga en cuenta lo siguiente:

- No toque la parte superior de la caja durante el funcionamiento.
- No tape las ranuras en la caja durante el funcionamiento.
- No ponga objetos debajo de la unidad.
- No tape las ranuras de ventilación de la parte superior de la unidad. No ponga nada a menos de 1 metro por encima del panel superior.
- Deje un espacio de unos 0,2 metro alrededor de la unidad.

## Italiano

Perché l'unità possa essere sempre ben ventilata, non installarla in scaffali o librerie e tenere presente quanto segue.

- Non toccare la parte superiore del rivestimento durante il funzionamento.
- Non bloccare le aperture sul rivestimento durante il funzionamento.
- Non inserire oggetti al di sotto dell'unità.
- Non bloccare le fessure di ventilazione sopra l'unità. Non posare nulla per circa un metro sopra il pannello superiore.
- Lasciare 0,2 metro liberi tutto intorno l'unità.

## Português

Para ventilar o aparelho, não instalá-lo dentro duma estante ou algo similar, e observar as seguintes recomendações:

- Não tocar a parte superior do aparelho durante a operação.
- Não bloquear as aberturas do aparelho durante a operação.
- Não inserir objectos debaixo do aparelho.
- Não bloquear as aberturas de ventilação na parte de cima do aparelho. Deixar um espaço completamente livre de cerca de 1 metro acima do painel superior.
- Deixar um espaço de cerca de 0,2 metro ao redor do aparelho.

## Svenska

För att ventilera enheten, ställ den inte i ett ställ eller bokhylla och tänk på följande.

- Vidrör inte ytterhöljets ovansida under pågående drift.
- Blockera inte öppningarna i ytterhöljet under pågående drift.
- Stick inte in föremål under enheten.
- Blockera inte ventilationshålen ovanpå enheten. Placera inte någonting närmare än 1 meter ovanför apparaten eller enheten.
- Se till att det finns omkring 0,2 meter fri plats runt omkring enheten.

## Dansk

Anbring ikke apparatet i et rack eller en boghylde, da dette kan bloke luftcirkulationen omkring apparatet. Iagttag ligeledes følgende:

- Berør ikke oversiden af kabinettet under anvendelsen.
- Bloker ikke åbningerne i kabinettet under anvendelsen.
- Stik ikke genstande ind under apparatet.
- Bloker ikke ventilationsåbningerne ovenpå apparatet. Anbring ikke noget nærmere end 1 m over apparatets overside.
- Sørg for, at der er et frit område på omkring 0,2 m omkring apparatet.

# CONNECTIONS FOR AUDIO COMPONENTS

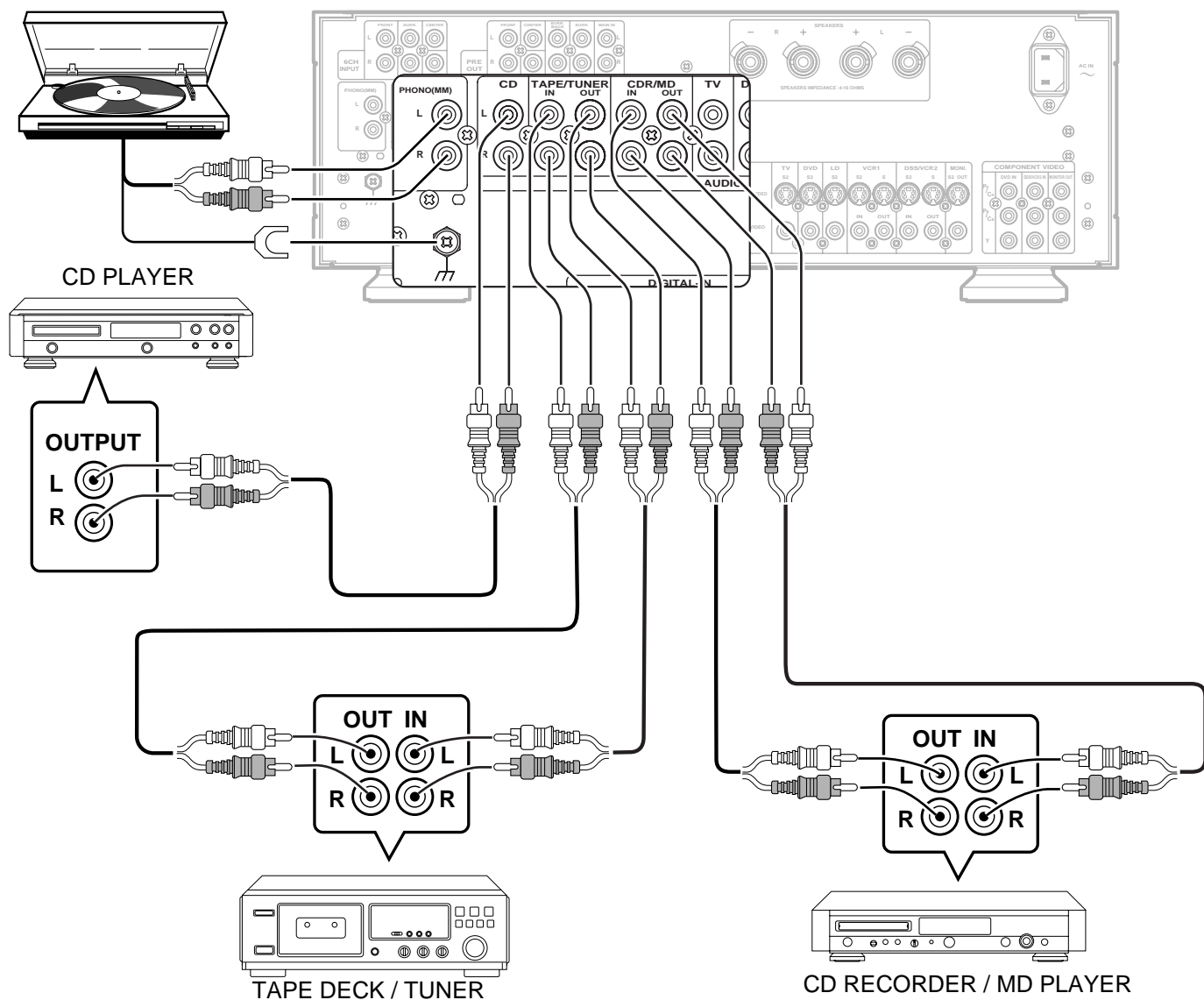

Ensure that the components are connected properly by checking which is the left channel (L) connection and which is the right one (R) and whether connection is to be made to the input (IN) or output (OUT) jacks. Refer to page V for details on the digital signal connections.

- The signals from the source played by the unit are output to the TAPE/TUNER-OUT and CD-R/MD-OUT jacks.

# CONNECTIONS FOR VIDEO COMPONENTS

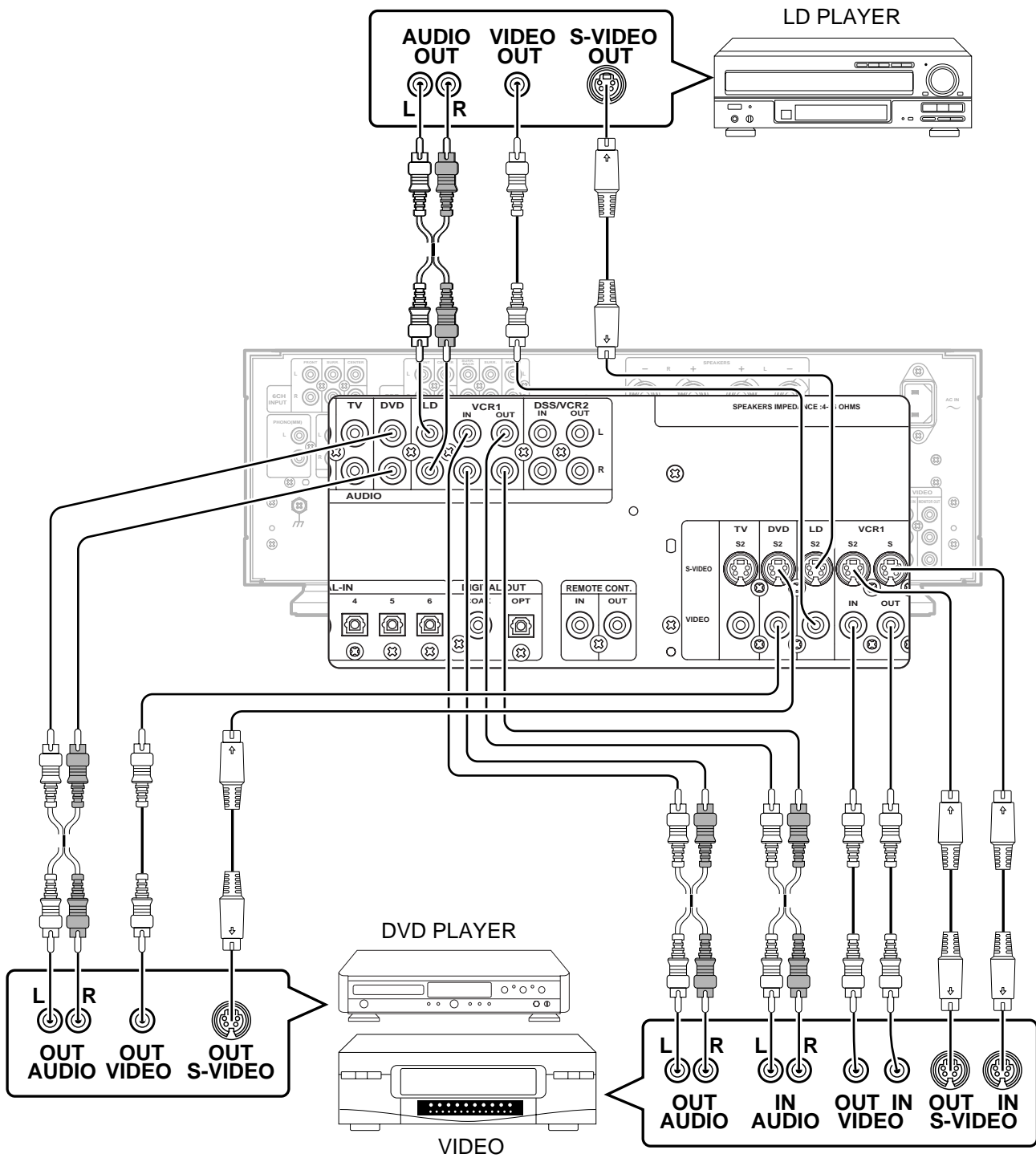

# CONNECTION FOR TV

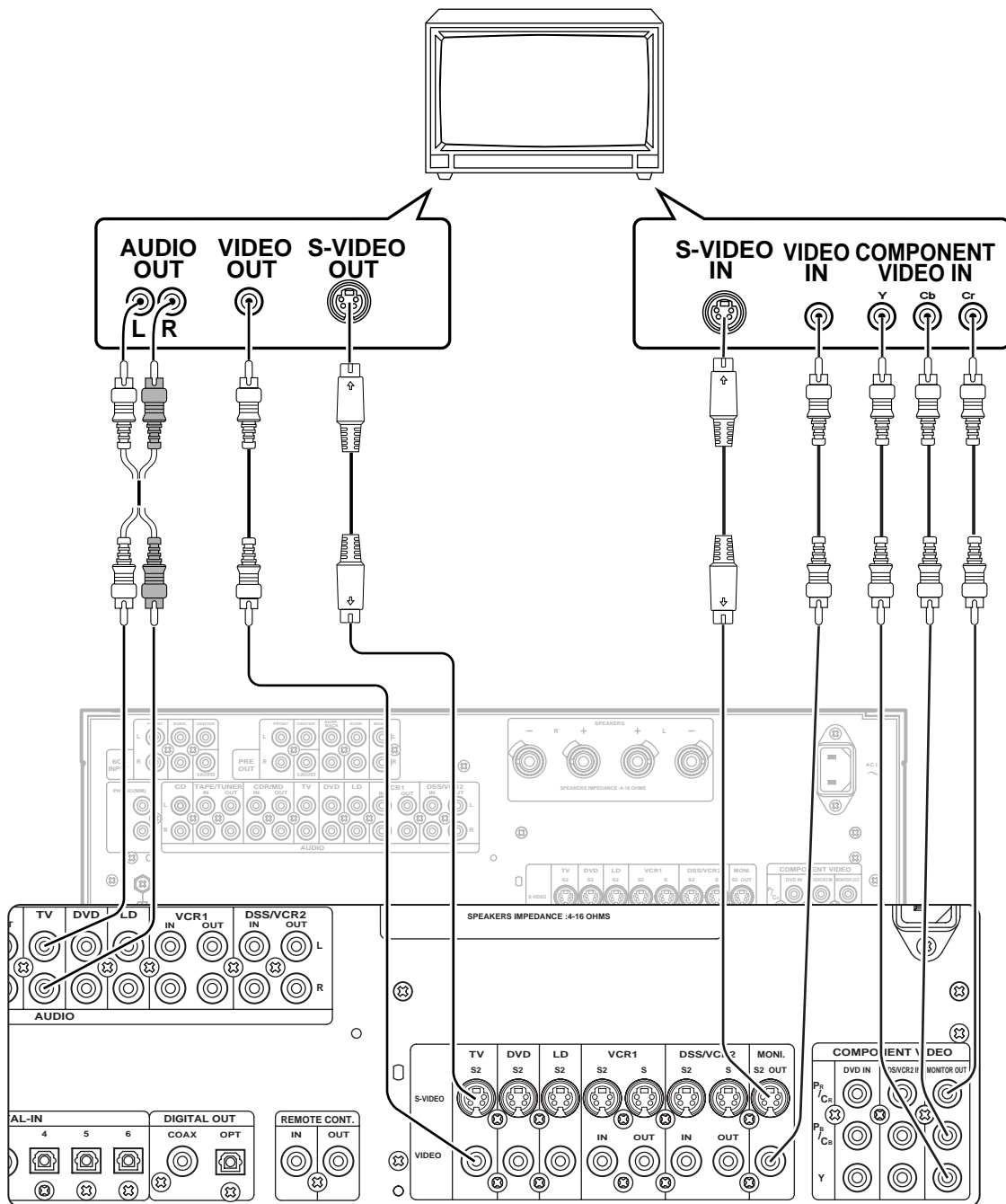

# CONNECTION WITH BS/CS TUNER AND COMPONENT VIDEO OUTPUT JACKS

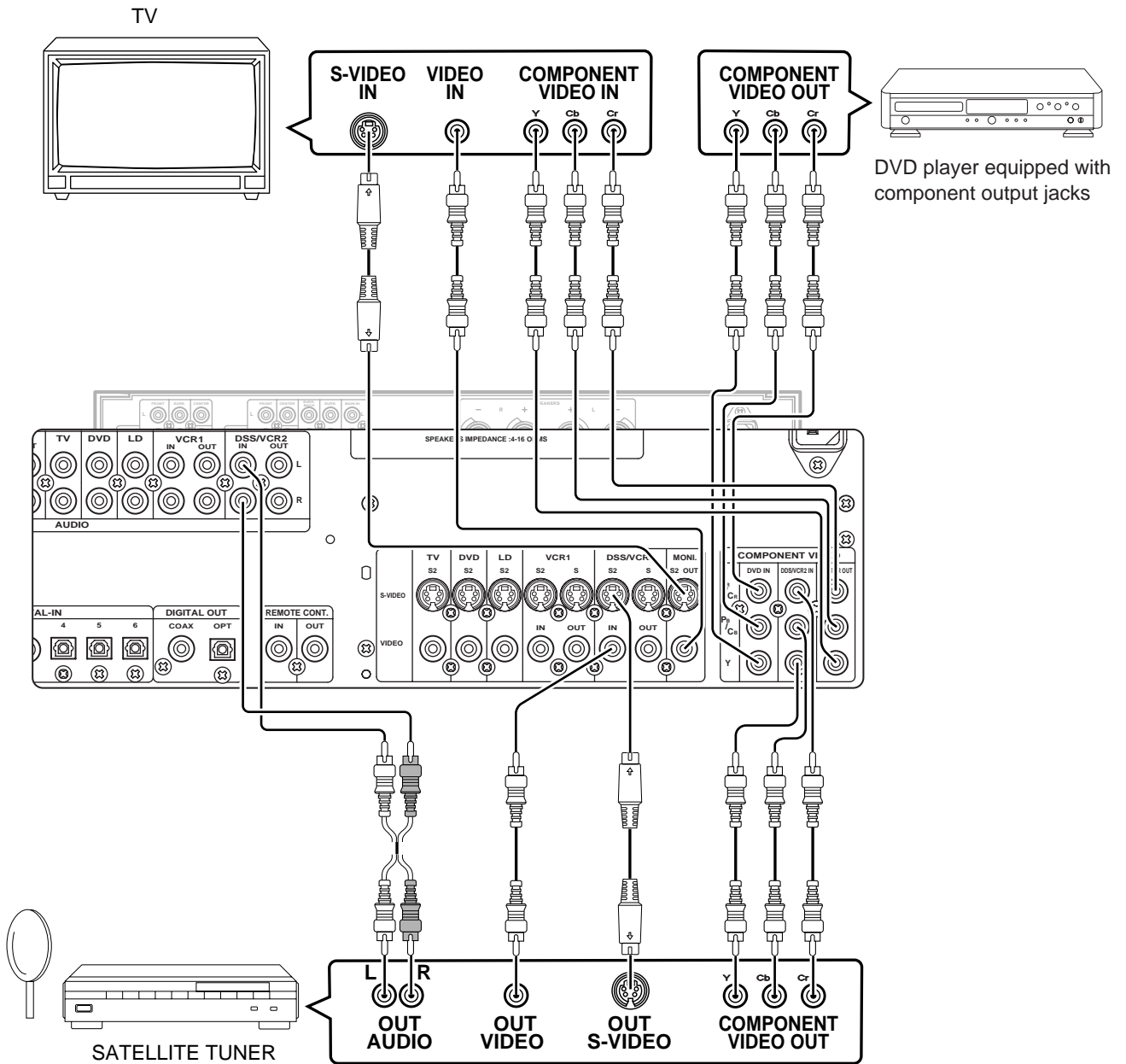

## CONNECTIONS FOR DIGITAL SIGNALS

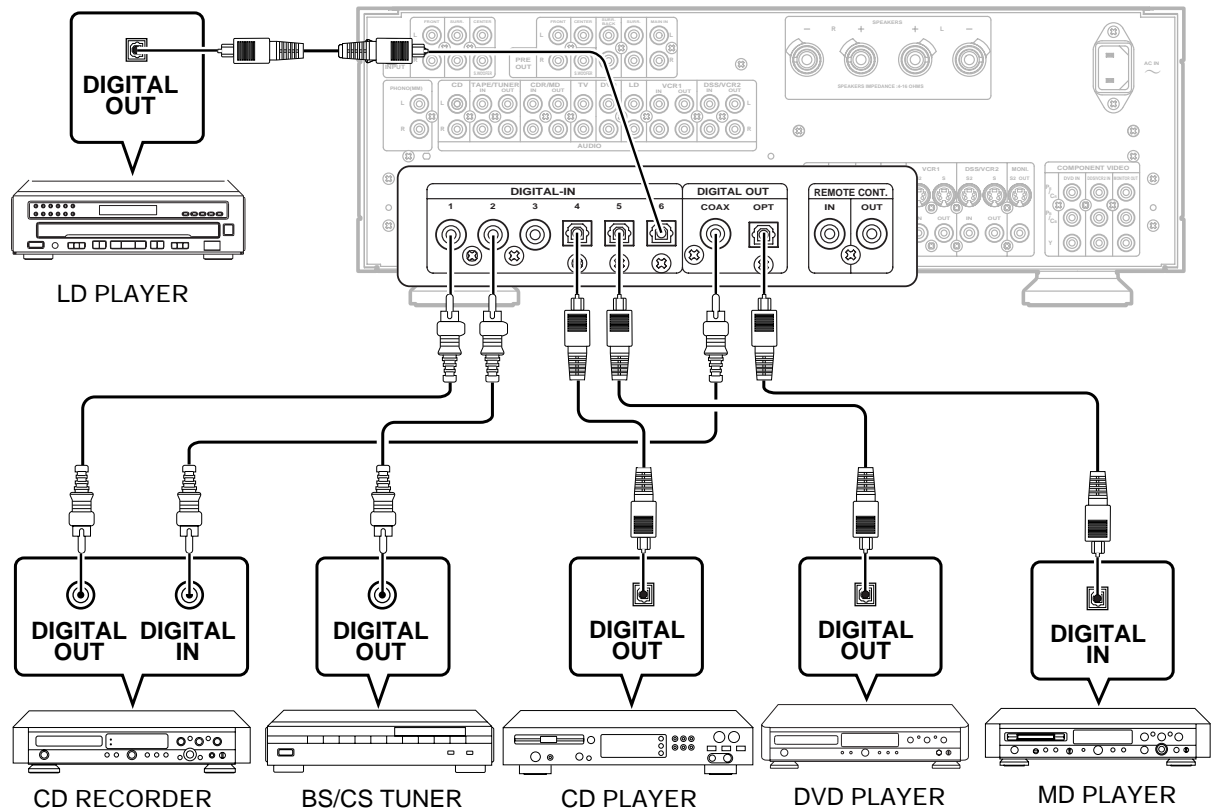

## CONNECTIONS FOR 6-CHANNEL EXTERNAL DECODER INPUT JACKS

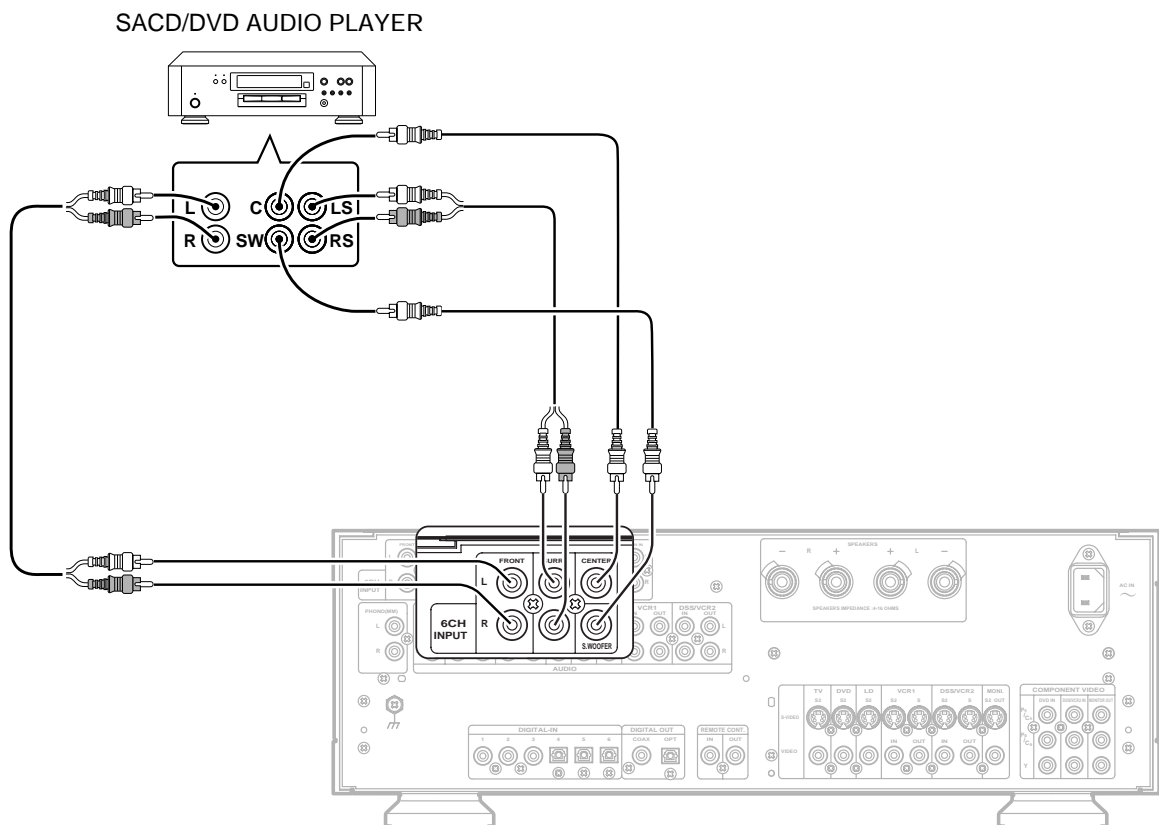



# REMOTE CONTROL CONNECTIONS

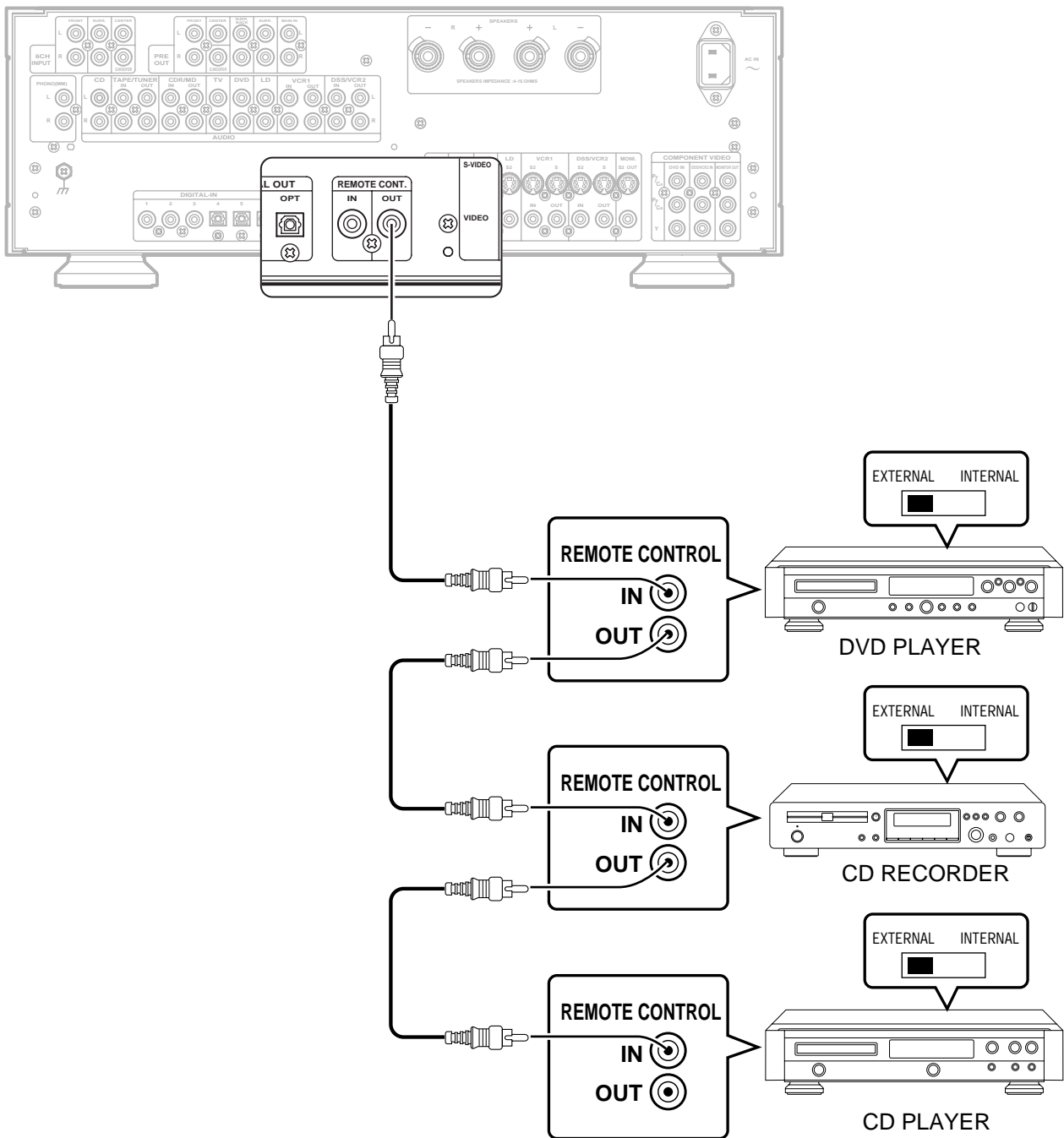

- As shown in the figure above, it is possible to connect the **REMOTE CONTROL** jacks on the unit with the corresponding jacks on other Marantz products. By performing these connections, all the other Marantz products can be controlled together using the accessory remote control unit.
- When these connections are to be performed, set the **REMOTE CONTROL SELECTOR** switch on each unit to **EXT** (external).
- Proceed with the connections while referring to the User Guide of each component to be connected as well.

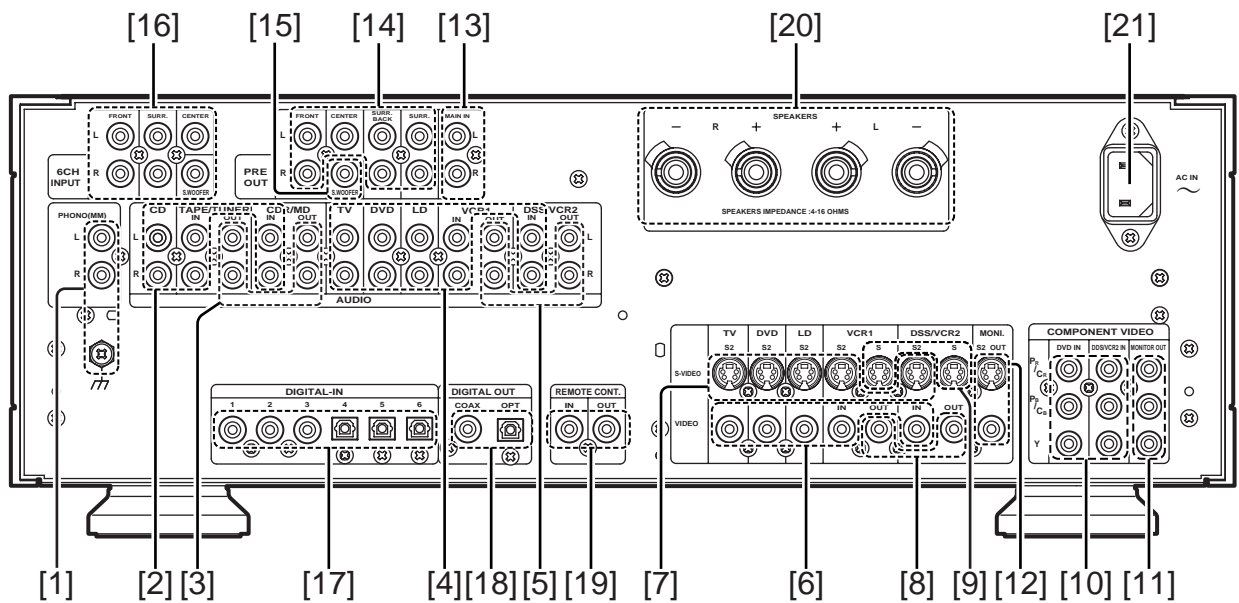
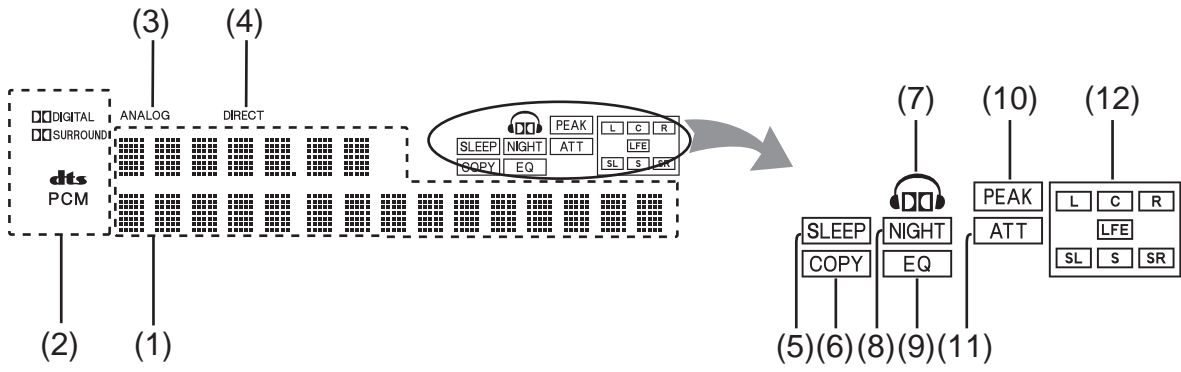
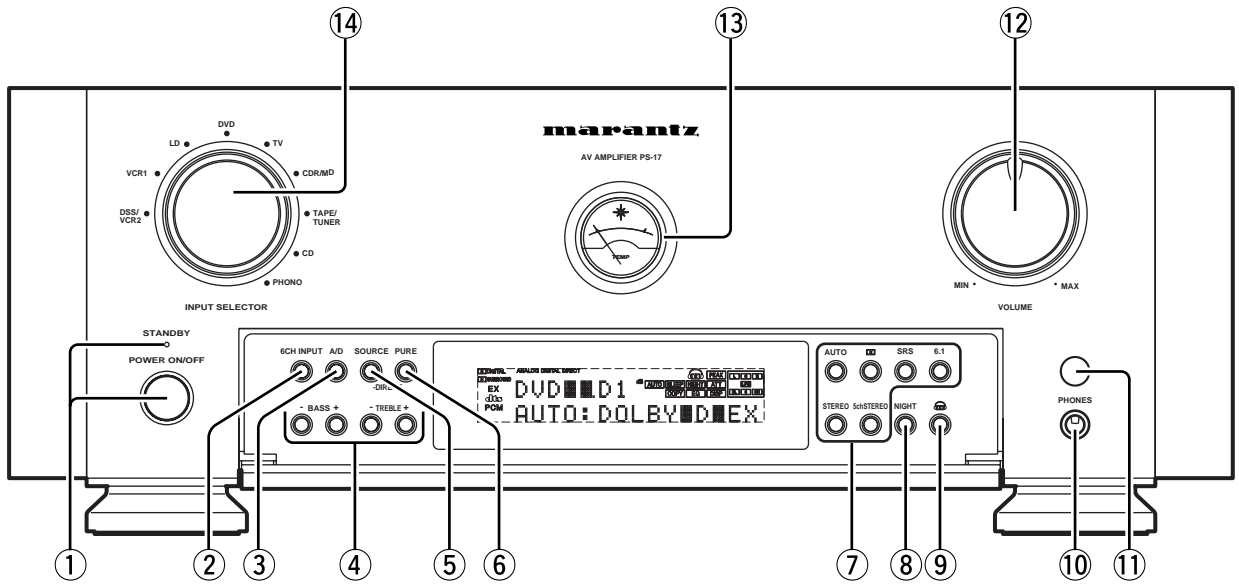

# TABLE OF CONTENTS

<b>INTRODUCTION</b> .....	<b>3</b>
<b>DESCRIPTION</b> .....	<b>3</b>
<b>FEATURES</b> .....	<b>3</b>
<b>FRONT PANEL FEATURES</b> .....	<b>4</b>
<b>DISPLAY</b> .....	<b>5</b>
<b>REAR PANEL CONNECTIONS</b> .....	<b>6</b>
<b>POSITIONING AND CONNECTING THE SPEAKERS</b> .....	<b>7</b>
<b>POSITIONING AND CONNECTING THE SPEAKERS (BASIC)</b> .....	<b>8</b>
<b>SPEAKER CONNECTIONS (BASIC)</b> .....	<b>9</b>
<b>POSITIONING AND CONNECTING THE SPEAKERS (APPLIED)</b> .....	<b>10</b>
<b>SET-UP</b> .....	<b>11</b>
ON SCREEN DISPLAY MENU SYSTEM .....	11
OSD MAIN MENU .....	12
SYSTEM SETUP .....	12
SPEAKER SETUP .....	13
SPEAKER DISTANCE .....	14
SURROUND MODE .....	14
CHANNEL LEVEL CONTROL .....	14
<b>BASIC OPERATION</b> .....	<b>15</b>
<b>SURROUND MODES</b> .....	<b>17</b>
<b>LISTENING THROUGH HEADPHONES</b> .....	<b>19</b>
<b>ON SCREEN DISPLAY INFORMATION</b> .....	<b>20</b>
<b>REMOTE CONTROL UNIT RC-17PS</b> .....	<b>21</b>
NAMES OF BUTTONS & FUNCTIONS .....	21
OPERATION OF REMOTE CONTROL UNIT .....	23
BASIC OPERATION .....	24
OTHER FUNCTIONS .....	30
BATTERY LIFE .....	30
NUMBER OF LEARNABLE CODES .....	30
JOG DIAL COMMAND FUNCTIONS LISTING .....	31
<b>TROUBLESHOOTING</b> .....	<b>32</b>

## FOREWORD

This section must be read before any connection is made to the mains supply.

### WARNINGS

Do not expose the equipment to rain or moisture.  
Do not remove the cover from the equipment.  
Do not push anything inside the equipment through the ventilation holes.  
Do not handle the mains lead with wet hands.

## EQUIPMENT MAINS WORKING SETTING

Your Marantz product has been prepared to comply with the household power and safety requirements that exist in your area. PS-17 can be powered by 230 V AC only.

### IMPORTANT: (For UK version)

This apparatus is fitted with an approved moulded 13 Amp plug. To change a fuse in this type of plug proceed as follows:

1. Remove fuse cover and fuse.
2. Fix new fuse which should be a BS1362 13A, A.S.T.A. or BSI approved type.
3. Refit the fuse cover.

If the fitted plug is not suitable for your socket outlets, it should be cut off and an appropriate plug fitted in its place.

If the mains plug contains a fuse, this should have a value of 13A. If a plug without a fuse is used, the fuse at the distribution board should not be greater than 5A.

#### Note:

The severed plug must be destroyed to avoid a possible shock hazard should it be inserted into a 13A socket elsewhere.

### How to connect a plug

The wires in the mains lead are coloured in accordance with the following code:

BLUE—"NEUTRAL" ("N")

BROWN—"LIVE" ("L")

1. The BLUE wire must be connected to the terminal which is marked with the letter "N" or coloured BLACK.
2. The BROWN wire must be connected to the terminal which is marked with the letter "L" or coloured RED.
3. Do not connect either wires to the earth terminal in the plug which is marked by the letter "E" or by the safety earth symbol or coloured green or green-and-yellow.

Before replacing the plug cover, make certain that the cord grip is clamped over the sheath of the lead — not simply over the two wires.

## COPYRIGHT

Recording and playback of any material may require consent. For further information refer to the following:

- Copyright Act 1956
- Dramatic and Musical Performers Act 1958
- Performers Protection Acts 1963 and 1972
- any subsequent statutory enactments and orders

### ABOUT THIS USER GUIDE

Refer to the figures on page iv of this user guide. The numbers on the figures correspond to those in the text. All references to the connections and controls that are printed in **BOLD** type are as they appear on the unit.

## PRECAUTIONS

The following precautions should be taken when operating the equipment.

### GENERAL PRECAUTIONS

When siting the equipment ensure that:

- the ventilation holes are not covered;
- air is allowed to circulate freely around the equipment
- it is on a vibration free-surface;
- it will not be exposed to interference from an external source;
- it will not be exposed to excessive heat, cold, moisture or dust;
- it will not be exposed to direct sunlight;
- it will not be exposed to electrostatic discharges

Never place heavy objects on the equipment.

If a foreign body or water does enter the equipment, contact your nearest dealer or service centre.

Do not pull out the plug by pulling on the mains lead, hold the plug. It is advisable when leaving the house, or during a thunderstorm, to disconnect the equipment from the mains supply.

### PRECAUTIONS IN CONNECTION

- Be sure to unplug the power cable from the AC outlet or turn off the POWER switch before proceeding with any connection.
- Connect one cable at a time observing the "input" and "output".  
This will avoid any cross connection between channels and signal inputs and outputs.
- Insert the plugs securely. Incomplete connection may result in noise.
- Prior to connecting other audio and video equipment to the PS-17, please read their owner's manuals.

## INSTALLATION

If this unit or another electronic device incorporating a microcomputer is used at the same time with the tuner or television, picture disturbance or noise may occur. In such a case, install the unit according to the following guide points.

- Separate the unit as far as possible from the tuner or television.
- Place the antenna wire for the tuner or TV apart from the power cable and audio and video connection cables of this unit.
- Since the phenomenon is likely to occur when using an indoor antenna and/or 300-ohm feeder wire, we recommend using an outdoor antenna and 75-ohm coaxial cable.

## INTRODUCTION

Thank you for purchasing the Marantz PS-17 DTS/Dolby Digital Surround amplifier.

This remarkable component has been engineered to provide you with many years of home theater enjoyment.

Please take a few minutes to read this manual thoroughly before you connect and operate the PS-17.

As there are a number of connection and configurations options, you are encouraged to discuss your own particular home theater setup with your Marantz A/V specialist dealer.

## DESCRIPTION



DTS was introduced in 1994 to provide 5.1 channels of discrete digital audio into home theater systems.

DTS brings you premium quality, discrete multi-channel digital sound to both movies and music.

DTS is a multi-channel sound system designed to create full range digital sound reproduction.

The no compromise DTS digital process sets the standard of quality for cinema sound by delivering an exact copy of the studio master recordings to neighborhood and home theaters.

Now, every moviegoer can hear the sound exactly as the moviemaker intended.

DTS can be enjoyed in the home for either movies or music on DVD's, LD's, and CD's.



Dolby Digital lets you enjoy Digital TV, Digital Satellite as well as DVD and LD software in digital surround, which is the next step above Dolby Pro Logic.

In comparison with Dolby Pro Logic, Dolby Digital can provide separate left and right surround channels, for more precise localization of sounds and a more convincing, realistic ambience. And, with Dolby Digital, all five main channels can be full range and a subwoofer can be added to each channel, if desired. By providing up to 5.1 channels of digital audio independently, Dolby Digital lets you enjoy better sound quality and more powerful presence than conventional Dolby Surround.

"Dolby", "AC-3", "Pro Logic" and the double-D symbol are trademarks of Dolby Laboratories.

"DTS" and "DTS Digital Surround" are trademarks of Digital Theater Systems, Inc.

"CS-5.1", "TruSurround Digital 5.1CH", "Circle Surround Virtual", "UltraSurround" and "SRS mark" symbol are trademarks of SRS Labs, Inc. "CS-5.1", "TruSurround Digital 5.1CH", "Circle Surround Virtual", "UltraSurround" technology is incorporated under license from SRS Labs, Inc.

## FEATURES

- Configured with the same twin monaural construction as a hi-fi stereo amplifier
- Built-in full-blown 2-channel current-feedback power amplifier incorporating HDAM which is original Marantz feature
- Rigid vibration-damping cabinet using extravagant amounts of aluminum employed for the chassis which houses the audio amplifier unit, DSP unit and video amplifier unit separately
- Super ring core toroidal power transformer as well as a separate power transformer for the digital unit
- Speaker terminals manufactured by WBT
- Flexible support for configurations ranging from a virtual amplifier where the unit is used as a discrete component to a full-channel system where it is combined with a power amplifier
- Surround sound effect reproduced through left and right speakers by Dolby Virtual processing when the unit is used as a discrete component
- Decoder/processor unit with a 3DSP configuration and sophisticated specifications
- 6.1 Channel Surround and CS (Circle Surround) decoders featured alongside Dolby Digital and DTS processing
- Dolby Headphone for a superior localization of sound beyond the confines of the user's head
- SRS UltraSurround and CS Virtual modes
- Model RC17PS learning remote control unit containing LCD display with macro functions

## FRONT PANEL (SEE PAGE VII)

### ① POWER switch and STANDBY indicator

You can turn on and off the unit's power using the front panel power switch.

However, if you turn the unit off with the front panel switch, the unit goes completely off rather than to the "standby mode" (Red LED indicator light glows in the standby mode).

The unit cannot be turned on with the remote control when it is not in the standby mode. When the red LED is on, the unit can be turned on via the remote control or by pressing any input selector button on the front panel.

### ② 6CH INPUT button

Press this button to select the output of an external multi channel decoder.

### ③ A/D (Analog/Digital) SELECTOR button

This is used to select between the analog and digital inputs.

#### Note:

This button is not used for an input source that is not connected to a digital input in the system setup 2/2.

The selection made with this button is not stored in the unit's memory. This means that the status which was set in the SYSTEM SETUP 2/2 will be restored when the input function is switched or after the unit has been placed in the standby mode.

### ④ BASS and TREBLE tone controls

These controls are used to boost or cut high and low frequencies.

**TREBLE:** Adjusts the tone of high-frequency sound.

**BASS:** Adjusts the tone of low-frequency sound.

#### Notes:

These buttons are disable in Source Direct mode, Pure Direct mode, SRS mode, Dolby Virtual mode, 6ch input, and Dolby Headphone mode.

Additionally these are not effective during playback of 96k PCM audio signal.

### ⑤ SOURCE DIRECT button

When this button is pressed, the tone control circuitry is bypassed as well as Bass Management.

### ⑥ PURE DIRECT button

This is used to select the PURE DIRECT mode.

In contrast to the SOURCE-DIRECT mode, the front panel display circuit is completely shut down, and then the video output circuit is shut down.

### ⑦ Surround MODE buttons (AUTO, $\square$ , SRS, 6.1, STEREO, 5ch STEREO)

Press the desired button to select surround mode.

### ⑧ NIGHT MODE buttons

This is used to select the NIGHT mode.

Selecting the Night Mode On is effective in Dolby Digital only, and it compresses the dynamic range.

This softens loud passages such as sudden explosions, to help prevent disturbing others late at night.

### ⑨ DOLBY HEADPHONE MODE buttons

This is used to select the operation mode of the Dolby Headphone when using headphones for listening.

### ⑩ PHONES jack for stereo headphones

Conventional dynamic headphones can be plugged in here.

### ⑪ INFRARED SENSOR window

This window receives infrared signals from the remote control unit.

### ⑫ VOLUME control knob

Adjusts the overall sound level. Turning the control clockwise increases the sound level.

The sound level operations can also be controlled from the provided remote control unit.

### ⑬ Warm-up meter

With any audio unit, the real sound quality cannot be obtained immediately after the power is turned on, and warming up is required to make the unit exhibit its full performance. As time passes after the power has been turned ON, the temperatures of different parts of the unit become constant and the electrolytic capacitors become active. This meter allows to check the warm-up condition of the unit.

The meter needle starts to swing gradually in a little while after the power is turned ON and reaches about 2/3 of the meter's full scale in about 30 minutes. Now the unit has almost been warmed up and can reproduce music with its original performance.

The meter positions immediately after turning power on and at the end of warming up and the time taken for warming up are variable depending on the temperature, ventilation and other conditions of the listening room where the unit is located.

### ⑭ INPUT SELECTOR knob

When this knob is turned, the input signal is switched in the following sequence.

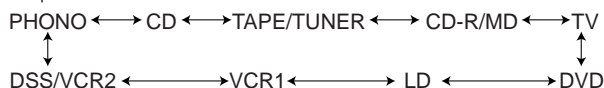

This knob can also be used to turn the unit's power on when it is in the standby mode.

# DISPLAY

## (1) Main Information Display

This display shows messages relating to the status, input source, surround mode, volume level or other aspects of unit's operation.

## (2) ENCODED SIGNAL indicators

**DIGITAL, SURROUND, dts and PCM**

When the selected input is a digital source, one of these indicators will light to display the specific type of signal in use.

## (3) ANALOG : Analog Input Indicator

This indicator lights when an analog input source has been selected.

## (4) DIRECT : SOURCE DIRECT Indicator

This indicator lights when the PS-17 is in the SOURCE DIRECT mode.

## (5) SLEEP Indicator

This indicator lights when the Sleep function is in use.

## (6) COPY Indicator

This indicator lights when DIGITAL COPY system is active.

## (7) D.H mark : DOLBY HEADPHONE Indicator

This indicator lights when headphones are used and the Dolby Headphone function is activated.

## (8) NIGHT Mode Indicator

This indicator lights when the PS-17 is in the Night mode, which reduces the dynamic range of digital program material at low volume levels.

## (9) EQ : HT-EQ (Home Theater EQ) indicator

This indicator lights when HT-EQ is active.

## (10) PEAK indicator

This indicator is a monitor for an analog audio input signal. If the selected analog audio input signal is greater than the capable level of internal processing, this will light. If this happens, you should press the **ATT** button on the remote controller.

## (11) ATT : Attenuation indicator

This indicator lights when the attenuation function is active.

## (12) ENCODED CHANNEL STATUS indicators

These indicators display the channels that are encoded with a digital input signal. If the selected digital input signal is Dolby Digital 5.1ch or DTS 5.1ch, "L", "C", "R", "LS", "RS" and "LFE" will light up. If the digital input signal is 2 channel PCM-audio, "L" and "R" will be displayed. If Dolby Digital 5.1ch signal with Surround EX flag comes in, "L", "C", "R", "LS", "S", "RS" and "LFE" will show.

## REAR PANEL CONNECTIONS

All connections to the rear panel should be made with the entire system powered off.

To avoid errors, it is advisable to connect one cable at a time between the various components.

### [1] PHONO input / GND (GROUND) terminal

Connect directly when the cartridge is MM (Moving Magnet) type. Use the Step-up transformer when the cartridge is MC (Moving Coil) type.

And connect the grounding wire from the Analog turntable to this terminal.

### [2] Three analog audio inputs

**CD, TAPE/TUNER, and CD-R/MD :**

Connect the audio outputs of your source components to the input jacks on the amplifier.

### [3] Two analog audio outputs for audio source equipment

**TAPE/TUNER and CD-R/MD :**

Connect each output to the audio inputs (REC in) of your recording equipment.

### [4] Five analog audio inputs for video source equipment

**TV,LD,DVD, VCR1, and DSS/VCR2 :**

Connect each input to the audio outputs of your video source equipment.

### [5] Two analog audio outputs for video source equipment

**VCR1, and DSS/VCR2 :**

Connect each output to the audio inputs (REC in) of your video recording equipment.

### [6] Five video inputs

**TV, DVD, VCR1, and DSS/VCR2 :**

Connect each input to the video outputs of your video source equipment.

### [7] Five S-video inputs

**TV, DVD, VCR1, and DSS/VCR2 :**

Connect each input to the S-video outputs of your video source equipment.

This unit's S-VIDEO input jacks support the S2 type. For details on the screen mode of the wide-screen TV set that is connected depending on the type of the external component's video system, refer to the User Guide of the playback component and TV set which are connected. These inputs are completely interchangeable with the conventional S-VIDEO inputs.

### [8] Two video outputs

**VCR1, and DSS/VCR2 :**

Connect each output to the video input (REC in) of your video recording equipment.

### [9] Two S-video outputs

**VCR1, and DSS/VCR2 :**

Connect each output terminals to S-video input (REC in) of your video recording equipment.

### [10] Two Component-video inputs

**DVD, DSS, VCR2 :**

Connect the Y/Cr/Cb component video output of each your video product to these jacks.

### [11] Component Video Outputs

Connect these outputs to the component video inputs of a video projector or monitor. When a source connected to one of the two Component Video Inputs is selected the signal will be sent to these jacks.

### [12] Monitor. (VIDEO/S-VIDEO) output jacks

Connect this jack to the composite or S-Video input of a TV monitor or video projector to view the on-screen menus and the output of any standard video source selected by the receiver's video switcher.

### [13] Main Amplifier Inputs:

Connect the pre-output jacks of your pre-amp to these jacks at the SEPARATE position of the system setup 1/2.

### [14] Preamp Outputs (L, R, SL, SR, SBL, SBR, C)

These jacks may be connected to an external power amplifier.

### [15] SUB WOOFER output jack

Connect to the input jack(s) of the power amplifier for subwoofer channel or powered subwoofer.

### [16] 6 CH INPUT jacks

Connect to the outputs of an external multichannel decoder or DVD player with multichannel decoder.

### [17] Six DIGITAL inputs

**Fig.1,2,3 (coaxial) and Fig.4,5,6 (Optical)**

Connect the digital output from a DVD player, HDTV receiver, LD player or CD player to these jacks. The signal may be either a Dolby Digital signal, DTS signal or a standard PCM digital source.

**Note :**

The coaxial connections are not for AC-3 RF from an LD, If you want to decode this type of signal, an external demodulator must be used.

### [18] Digital Audio Outputs (Optical, Coaxial)

Connect these jacks to the matching digital input connector on a digital recorder such as a CD-R or Mini Disc recorder.

### [19] REMOTE CONT. IN/OUT terminals

Connect to a Marantz component equipped with remote control (RC-5) terminals.

### [20] Speaker Outputs terminals

Connect to the left and right speakers.

### [21] AC INLET

Connect the provided detachable power cord, and connect the AC plug to an unswitched AC wall output.



# POSITIONING AND CONNECTING THE SPEAKERS

The ideal number of channels in a system for reproducing surround sound with this unit is 8, namely, the front left and front right, center, left surround and right surround, back left and back right surround, and subwoofer.

The number of speakers minimally required in a system for surround sound reproduction is 4, namely, the front left and right speakers and the left and right surround speakers. However, 6.1-channel surround sound cannot be reproduced with this kind of setup.

With this unit, the system is set to match the number and positions of the speakers and the output characteristics of their bass range.

## POSITIONING THE SPEAKERS

The speakers are placed in different positions depending on the size of the room and other factors present. The basic layout of the speakers and some layout tips are given below.

### Layout tips

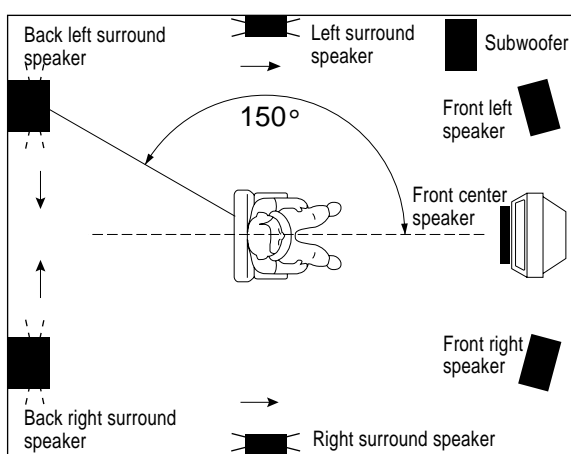

### Front left and right speakers

It is recommended that these speakers be positioned at an angle of 45 to 60 toward the rear as seen from the listening position.

### Center speaker

This is placed with its front aligned with the front left and right speakers or slightly offset to the rear.

### Left and right surround speakers

These are placed somewhere between the sides of the listening position and the front. They are not placed behind the listening position.

### Back left and right surround speakers

These are positioned behind the listening position. Place them at the angles shown in the figure.

### Subwoofer

Use of a subwoofer is recommended in order to maximize the bass effect. The subwoofer handles only the bass range so it can be placed anywhere in the room.

## HEIGHT

### Front speakers (left, right and center)

The midrange and high-range speaker units of the three front speakers should be arranged at the same height as far as this is possible.

This means placing the center speaker either directly on top of the TV set or directly underneath it.

A layout like this necessitates the use of the kind of center speaker which is protected from magnetic fields.

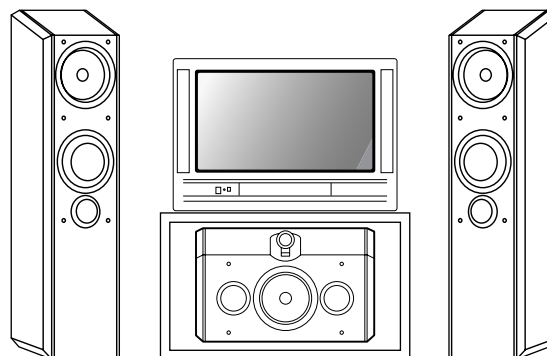

### Surround speakers

These should be positioned about 70 cm to a meter above the listener as space allows. This will ensure that the sound field will not be conspicuously localized but perceived as pervading the whole room.

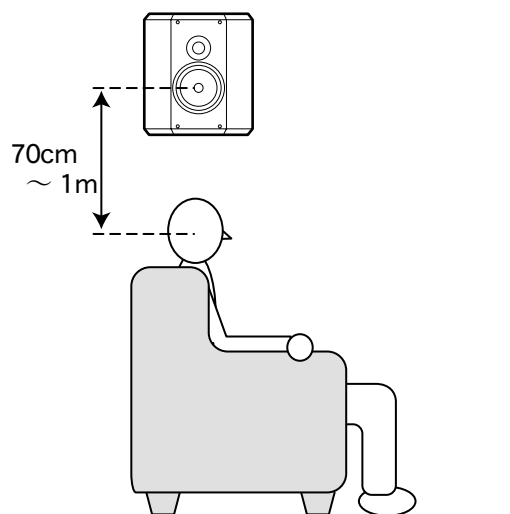

# POSITIONING AND CONNECTING THE SPEAKERS (BASIC)

## CONNECTION OF SPEAKER SYSTEMS

- The speakers in the speaker system should have an impedance between 4 and 16 ohms. If speakers with an impedance of less than 4 ohms are connected, the protection circuit may be activated during play.
- The output terminals have positive (⊕: Red) and negative (⊖: white) polarity, and each speakers also has the same polarity (⊕ and ⊖). When connecting the speaker, be sure to connect the terminals with the same polarity (⊕ with ⊕, ⊖ with ⊖).

### CAUTION:

When connecting two pairs of speaker systems simultaneously, the impedance of each speaker system should be no less than 8 ohm . Connecting a speaker system with a lower impedance than 8 ohm may activate the protection circuitry and make normal stereo reproduction impossible.

## CONNECTION OF SPEAKER CORD

 Strip coating from extremity.

 Twist conductors.

Speaker cord

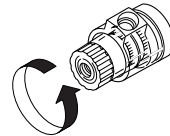

Turn counter-clockwise to loosen.

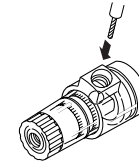

Insert conductors.

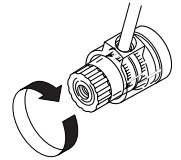

Turn clockwise to tighten.

Banana plugs can also be used in the same way.

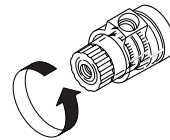

Turn counterclockwise to loosen.

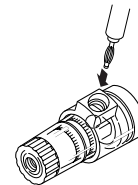

Insert the banana plug.

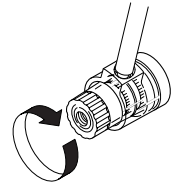

Turn clockwise to tighten.

## WHEN USING ONLY THE FRONT LEFT AND RIGHT SPEAKERS

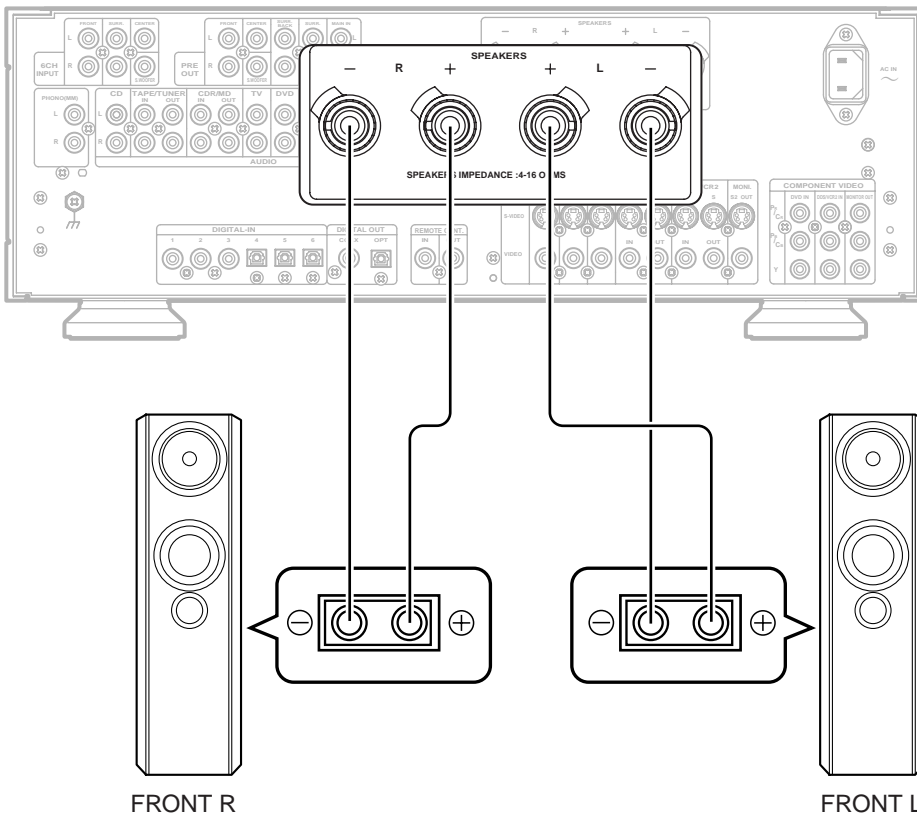

When the components have been connected as shown above, select NONE for SUB WOOFER, NONE for CENTER, NONE for SURROUND and NONE for SURR.BACK as the settings for SPEAKER SETUP described later.

SPKRS SETUP	
SETUP	: UNLOCKED
SUBWOOFER	: NONE
CENTER	: NONE
SURROUND	: NONE
SURR.BACK	: NONE
NEXT	

# SPEAKER CONNECTIONS (BASIC)

When using the unit's internal power amplifier for the front left and right speakers, and an external power amplifier for connection to the center speaker, left and right surround speakers, back surround speakers and subwoofer with internal amplifier

\* Select YES for SUB WOOFER, YES for CENTER, YES for SURROUND and 1ch for SURR.BACK as the settings on SPEAKER SETUP 1/4 of the OSD menu system.

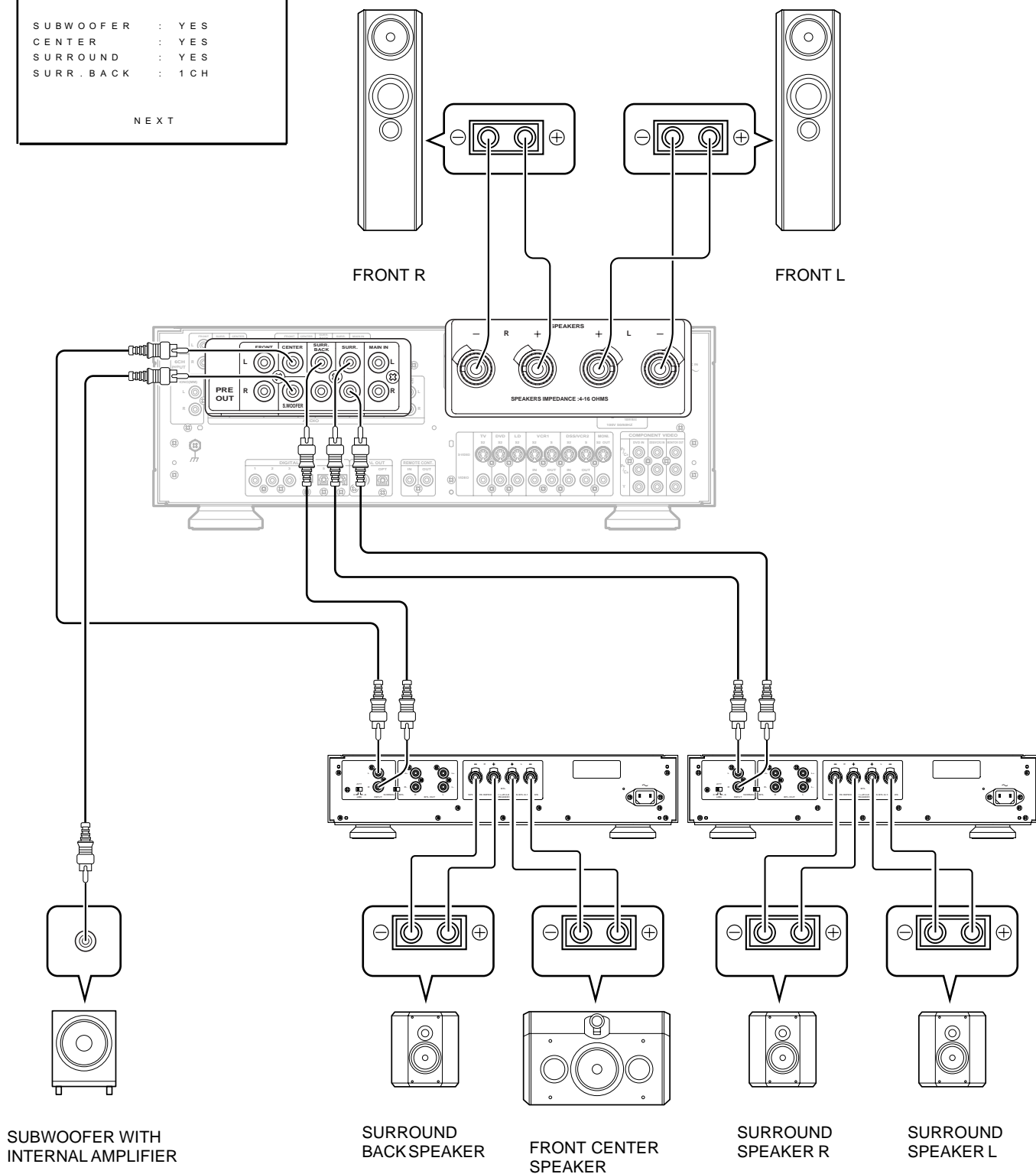
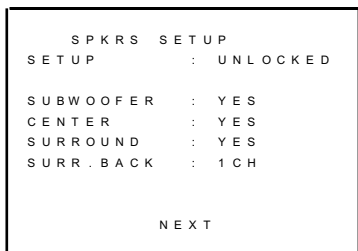

# POSITIONING AND CONNECTING THE SPEAKERS (APPLIED)

## SPEAKER CONNECTIONS (APPLIED)

### WHEN USING THE UNIT'S INTERNAL POWER AMPLIFIER FOR THE LEFT AND RIGHT SURROUND SPEAKERS

- The external power amplifier is used for the front left and right speakers, center speaker, back left and right surround speakers and subwoofer.
  - Insert the supplied short plugs between the SURROUND L and MAIN IN-L jacks and between the SURROUND R and MAIN IN-R jacks in the PRE OUT jack section.
- Next, select SEPARATE as the MAIN IN setting on SYSTEM SETUP 1/2 of the OSD menu system. (Page 12) The left and right surround signals are now output from the unit's speaker terminals.

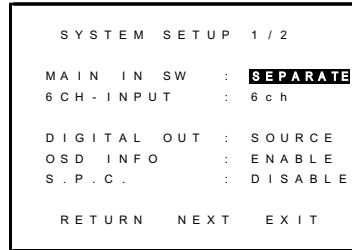

**Note:**

Use the supplied short plugs for the above application only and no other. Otherwise, trouble may be caused.

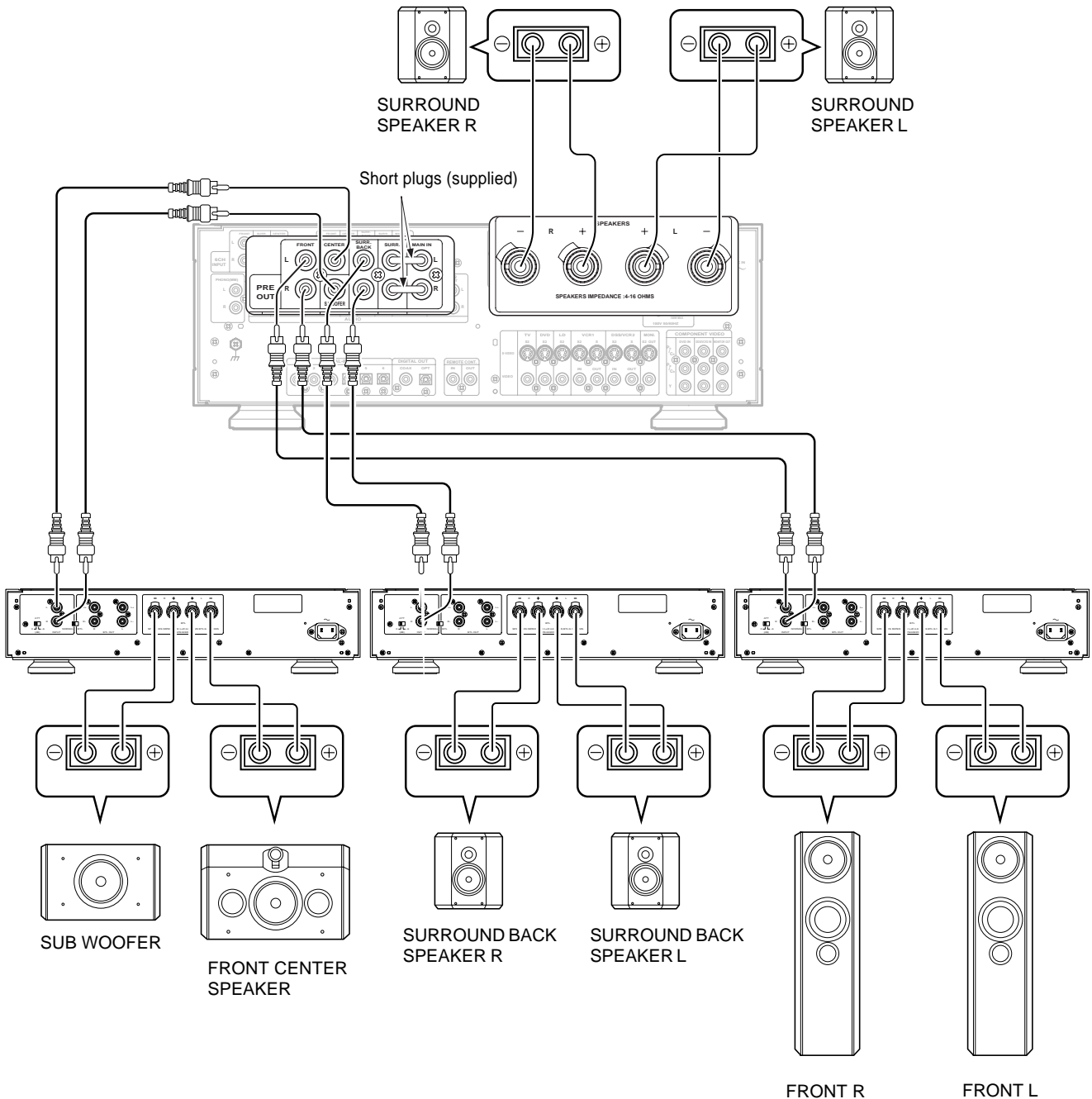

# SET-UP

After all components are connected, initial setup must be performed.

## ON SCREEN DISPLAY MENU SYSTEM

The PS-17 incorporates an on-screen menu system, which makes various operations possible by using the cursor (←, →, ↑, ↓) and **OK** buttons on the remote controller.

The settings made with these buttons are also shown in the on-screen display.

### Note:

Each video input function is set PAL or NTSC for TV format of OSD. If this setup does not meet the video input signal, character of OSD can not synchronize.

So you can select these format function by function.

Press **OSD** button **[17]** on the remote controller for 3 seconds or more. "PAL" or "NTSC" will be shown on the FL display of PS-17, press **OSD** button **[17]** again to change the TV format.

The indicator on FL display will change "PAL" fi "NTSC" fi "PAL" fi . This setup is memorized with each video input function.

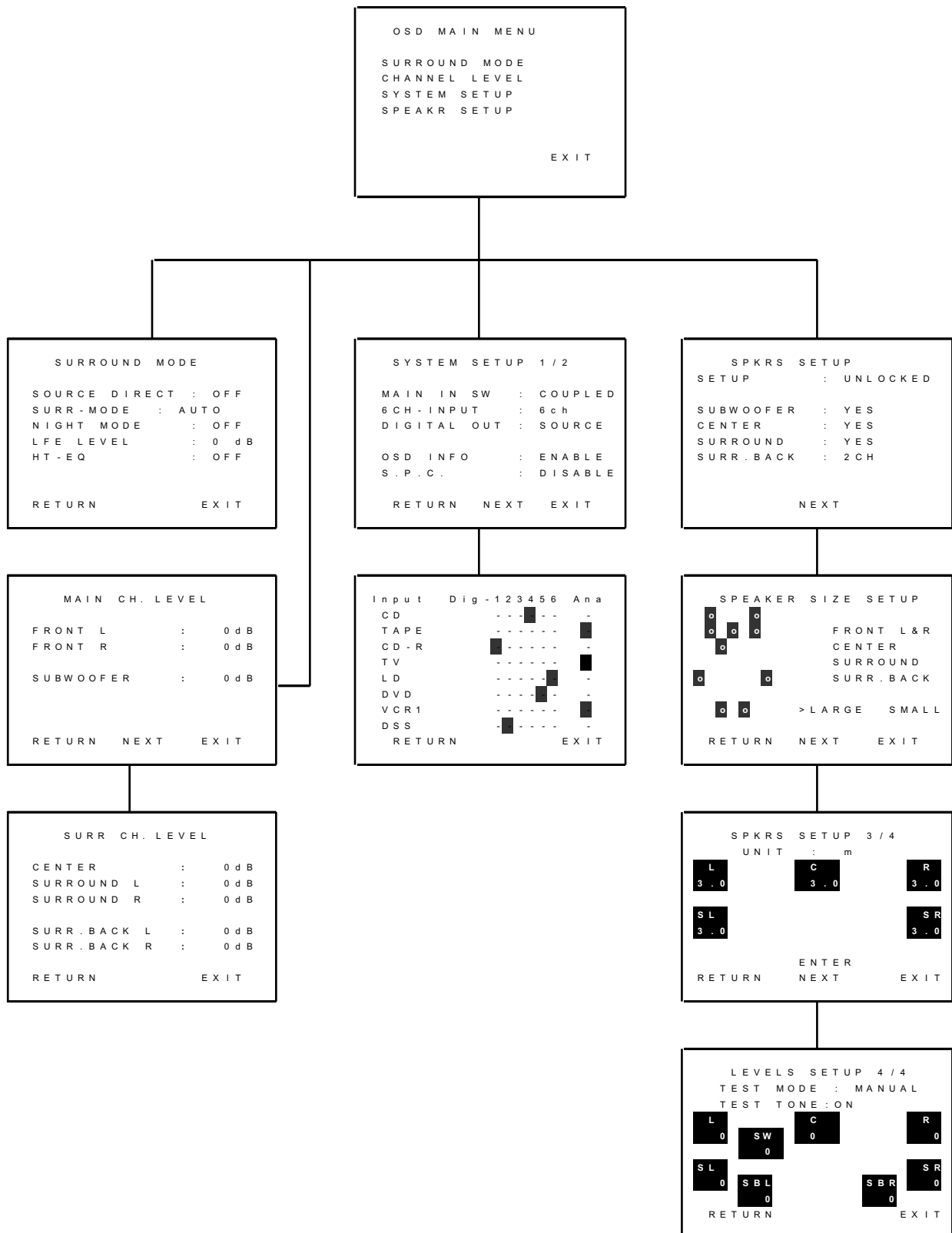

## OSD MAIN MENU

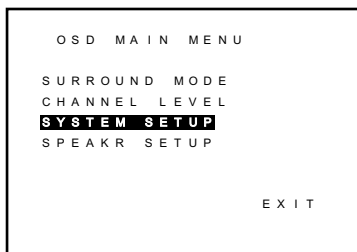

1. Press the **AMP** button [8].
2. Press any one of the cursor buttons (<, >, ^, v and **OK** buttons) to display the "MAIN MENU" of the on-screen display menu. Choose a desired item in the contents with ^ or v button, and press the **OK** button to select. Display will change to menu for each item.

## SYSTEM SETUP

### SYSTEM SETUP 1/2

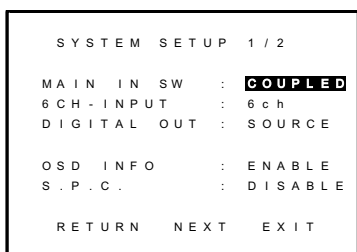

#### MAIN IN SW : CUPPLE > SEPARATE

This selects the connection to the unit's internal 2-channel amplifier.

**COUPLED:** This setting is used when the internal amplifier is to be used for the unit's left and right channel applications.

**SEPARATE:** This setting is used when the internal amplifier is to be used for the unit's MAIN INPUT applications. Select it when the internal amplifier is to be used for surround channel applications by means of the supplied short plugs.

#### 6CH. INPUT : 6CH > 2CH

The 6 channel input of the PS-17 can be selected to use a 6channel input or front 2channel input. Select 6channel use or 2channel use by < or > button.

**DIGITAL OUT :** This lets you chose which digital input will be output for digital recording.

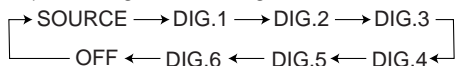

To determine each source, display the desired source and press the < or > button.

**OSD Info :** If you select enable, PS-17 will display the status of the feature (Volume up/down, input select, etc..) on the TV monitor. But if you do not desire this information, select "DISABLE".

#### S.P.C. : ENABLE > DISABLE

System Power Control : If you select "ENABLE", the PS-17 will output a power On/Off command for a CD player, MD player, or DVD player, from the remote output terminal.

If you have corresponding marantz products, you can turn them on/off simultaneously with PS-17.

#### NEXT/RETURN/EXIT

**NEXT:** Move cursor to here, and press "ok" button to go to SPEAKERS SETUP 2/2.

**RETURN:** If you desire to return the main menu, press the "ok" button on **RETURN**

**EXIT:** If you desire to exit from OSD menu system, press the "ok" button on EXIT.

#### SYSTEM SETUP 2/2 (SELECTING DIGITAL INPUT)

Six digital inputs can be assigned as the desired source.

Use this menu to set the PS-17 for connected equipment and type of connection.

Input	Dig - 1	2	3	4	5	6	Ana
CD	-	-	-	■	-	-	-
T A P E	-	-	-	-	-	-	■
CD - R	■	-	-	-	-	-	-
T V	-	-	-	-	-	-	■
L D	-	-	-	-	■	-	-
D V D	-	-	-	■	-	-	-
V C R 1	-	-	-	-	-	-	■
D S S	-	-	-	-	-	-	-
RETURN	■	-	-	-	-	-	-
							EXIT

#### Example;

When the digital output of a DVD player is connected to Digital 4 (input jack) of the PS-17;

1. Move the cursor on the line of the DVD with cursor buttons ^ or v.
2. Move the cursor on "Dig 4" with cursor buttons < or >.
3. Press the **OK** button to chose.
4. If you desire to continue the next setup, press the **OK** button on **RETURN**.

If you desire to exit from OSD menu system, press the **OK** button on EXIT.

#### Notes

- The PHONO is fixed to the analog input, and cannot be selected for any digital input.
- When a DTS-LD or DTS-CD is playing, this setup is not available. This is to avoid noise being generated from the analog input. In this case, the DTS audio must be played through the player's digital output to the digital input on the PS-17. This is because the DTS soundtracks replace the standard PCM soundtracks on DTS discs.
- The PS-17 does not switch from digital input to analog input or vice versa automatically. In case both digital and analog inputs are connected to the PS-17, if you desire to switch to analog input temporarily, you can do so by pressing the **A/D** button.

## SPEAKER SETUP

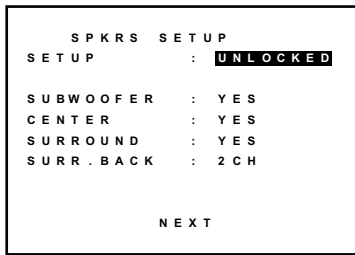

First, set whether the speakers are connected to the connected channels.

### SPEAKER SETUP 1/4

**SETUP:** Select "LOCKED" with < or > button in order to lock the contents of the SPKR SET UP MENU. Then, when you want to change the contents of this setup, select "UNLOCKED".

#### SUBWOOFER : YES > NONE

Select "YES" with < or > button if a subwoofer is connected to your system, select "NONE" subwoofer is NOT connected to your system.

#### CENTER : YES > NONE

Select "YES" with < or > button if a subwoofer is connected to your system, select "NONE" subwoofer is NOT connected to your system.

#### SURROUND : YES > NONE

Select "YES" with < or > button if a subwoofer is connected to your system, select "NONE" subwoofer is NOT connected to your system.

#### SURR. BACK : Select the number of surround back channels, "2ch", "1ch" or "NONE", with < or > button.

If you have two one speakers for the surround back channel, select "2CH".

If you have only one speaker for the surround back channel, select "1CH"

**(Note:** If 1CH is selected, the signal of surround back will go out from pre output of surround back L ch only. In that case, connect your external amplifier to this output terminal.)

Select "NONE", if a surround back speaker is NOT connected to your system.

**(Note:** If the surround back speaker is selected "NONE", 6.1 Surround mode is not available.)

These speakers are very effective for reproducing signals which have been processed by Dolby Surround EX or DTS-ES.

## SPEAKER SIZE SETUP

### SPEAKER SETUP 2/4

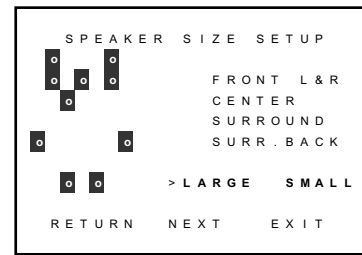

### SPKR SIZE

This menu enters the information about which type of speakers will be used for each channel.

In turn, these settings will determine which speakers receive low frequency information.

For the purpose of establishing proper bass reproduction, use the LARGE settings if the speaker being used at any position is a traditional full-range loudspeaker that is capable of reproducing sound below 100 Hz and you are not using a subwoofer.

Use the SMALL setting for smaller, frequency-limited speakers that are not able to reproduce sounds below 100Hz and you are using a subwoofer. Low frequencies will be diverted from the speaker to the subwoofer.

Note that when "small" speakers are used it is advisable to install a separate subwoofer, especially if you wish to appreciate the full impact of a good home theater soundtrack.

#### FRONT -L/R : LARGE > SMALL

Select the size of front L/R speakers, "SMALL" or "LARGE" with < or > button.

#### CENTER : Select the size of Center speaker, "SMALL" or "LARGE" with < or > button.

#### SURR-L/R : Select the size of Surround L/R speakers, "SMALL" or "LARGE" with < or > button.

#### SURR.BACK-L/R : Select the size of Surround back speaker(s), "SMALL" or "LARGE" with < or > button.

### Notes:

The SUBWOOFER cannot be set to None when the front speakers are set to SMALL.

This speaker size setup is not effective when the SOURCE-DIRECT or 6CH. Input is selected.

## SPEAKER DISTANCE

### SPEAKER SETUP 3/4

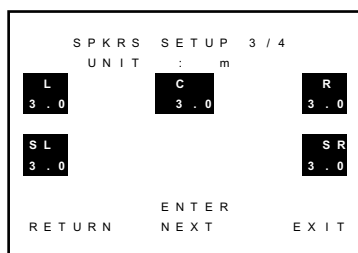

#### Speaker distance for time alignment

Use this parameter to specify the distance of the speaker's position from the listener.

The delay time is automatically set according to these distances.

**UNITS:**The units may be selected with **OK** button, and input each speaker's distance with **<** or **>** button.

If you select "m", it will change in 0.3 meters increments. If you select "ft" it will change in 1foot increments.

Select speaker with **OK** button, and input each speaker's distance with **<** or **>** button.

When the input for each speaker's distance has been finished, move the cursor to **ENTER** and press the **OK** button.

#### NOTES :

If your are out of range, the OSD text will blink.

Placement beyond that distance is beyond the range of the automatic time delay feature.

The delay feature does not function in the SOURCE-DIRECT ,6 CH-Input modes and decoding of 96 kHz sources.

## LEVELS SETUP

### (SPEAKER SETUP 4/4, TEST TONEGENERATOR)

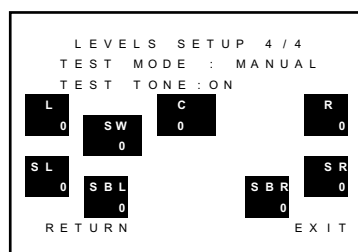

#### TEST MODE : AUTO > MANUAL

Selects the mode for generating the test tone. If you select **AUTO** with **<** or **>** button, the test tone will be cycled through in a circular pattern which is Left Center Right Surround Back Right Surround Back Left Surround Left Subwoofer Left ...in increments of 3 seconds for each channel.

If you select **MANUAL**, press the **OK** button to cycle through the test tone channels after the "TEST TONE ON".

**TEST TONE:** Press the **Ok** button, ON is indicated and the test tone starts from the front left speaker.

Press the **Ok** button again on this item. OFF is indicated and the output of the test tone will stop.

**Level adjust :** Adjust the level of the test tone for each channel with the **<** or **>** buttons.

#### Notes:

- The setup level for each channel is memorized for reproduction in all surround mode.
- These levels are common for all surround modes, except 6CH-INPUT mode.

## SURROUND MODE

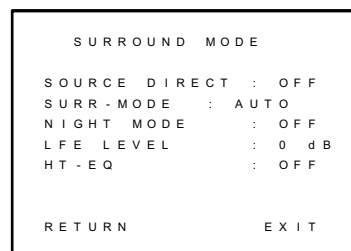

#### SOURCE DIRECT : ON > OFF

Switch the source direct ON or OFF with **<** or **>** button.

In this mode, PS-17 bypasses the digital processing and crossover for the main speakers (front left and right will be full range and the subwoofer will be ON)

#### Note:

Source Direct mode will be off if Surround mode is changed.

#### SURR-MODE : Select the surround mode with < or > button.

Surround mode will change by scrolling as follow.

#### e.g.

AUTO fi DOLBY fi 6.1 fi SRS fi 5CH STEREO fi STEREO

#### NIGHT MODE : ON > OFF

Switch the NIGHT MODE ON or OFF with **<** or **>** button.

Selecting the Night Mode ON is effective in Dolby Digital only, and it compresses the dynamic range.

This softens loud passages such as sudden explosions, to help prevent disturbing others late at night.

#### LFE LEVEL : 0dB > -10dB

Select the output level of the LFE signal included in the Dolby Digital signal or the DTS signal. Select 0dB, -10 dB or OFF with **<** or **>** button.

#### HT-EQ: ON > OFF

Switch the HT (Home Theater) - EQ on or off with **<** or **>** button.

This mode compensates for the audio portion of a movie sounding "bright".

This equalizer is effective in AUTO, DOLBY, DTS, 6.1 and STEREO mode.

## CHANNEL LEVEL CONTROL

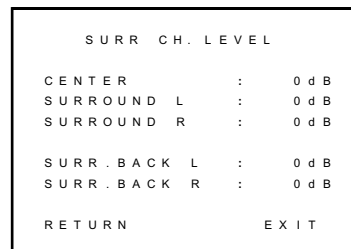
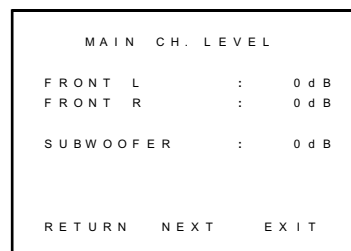

Desired channels can be selected by pressing **▲** or **▼** button. Each channel level will be adjusted by pressing **<** or **>** button. Only the usable channels which are determined depending on the SURROUND mode, and SPEAKER SETTING are displayed.



# BASIC OPERATION

## PLAYBACK OPERATION

This is playback in the stereo mode.

### Playing the analog disk/Analog input.

1. Press the POWER ON button on the remote. When the red LED is on, the unit can be turned on" by pressing any input selector knob on the front panel.
2. Set the **INPUT SELECTOR** knob to **PHONO** on the front panel or press the **PHONO** of **FUNCTION** buttons twice on the remote unit.
3. Press the **SOURCE DIRECT** of Surround mode buttons on the front panel or press the P-DIRE on the remote unit in the AMP MODE.



4. Play the analog turntable.
5. Adjust the volume level using the **VOLUME** knob (12) on the front panel or press the **VOL ▲/▼** button (9) on the remote.

### Caution for analog disk play

- Reduce the volume to the minimum position before replacing the cartridge or placing the stylus on the disk.
- Do not apply shock to the turntable during play. Otherwise the stylus may jump and damage the disk surface.
- Avoid installing the turntable near a speaker, for this may cause howling and make it impossible to increase the listening volume.
- Do not turn power of the turntable off while the stylus is placed on a disk.

### Playing the CD player/Digital Input.

1. Set the **INPUT SELECTOR** knob to **CD** on the front panel or press the **CD** of **FUNCTION** buttons twice on the remote unit.
2. Press the **AUTO** of Surround mode buttons on the front panel or press the **AUTO** on the remote unit in the AMP MODE.

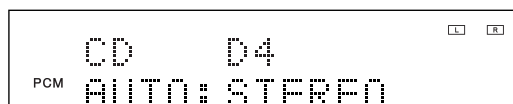

3. Play the CD Player.
4. Adjust the volume level using the **VOLUME** knob (12) on the front panel or press the **VOL ▲/▼** button (9) on the remote. If necessary, adjust the tone, select the **TRB+**, **TRB-** and **BAS+**, **BAS-** by the **Jog Dial** (6) and press **ENT** button (7) in the AMP MODE on the remote unit.

This is playback in the Multi-channel mode/Digital Input.

### Playing the DVD player/Digital Input.

1. Set the **INPUT SELECTOR** knob to **DVD** on the front panel or press the **DVD** of **FUNCTION** buttons twice on the remote unit.
2. Press the **AUTO** of Surround mode buttons on the front panel or press the **AUTO** on the remote unit in the AMP MODE.

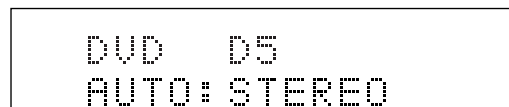

3. Play the DVD Player.

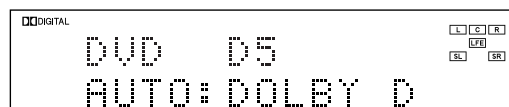

4. Adjust the volume level using the **VOLUME** knob (12) on the front panel or press the **VOL ▲/▼** button (9) on the remote. If necessary, adjust the tone, select the **TRB+**, **TRB-** and **BAS+**, **BAS-** by the **Jog Dial** (6) and press **ENT** button (7) in the AMP MODE on the remote unit.

### Playing the DVD player/6ch-INPUT.

1. Set the **INPUT SELECTOR** knob to **DVD** on the front panel or press the **DVD** of **FUNCTION** buttons twice on the remote unit.
2. Press the **6CH-INPUT** on the front panel. Select the **6-DIR** by the **Jog Dial** (6) and press **ENT** button (7) in the AMP MODE on the remote unit.



3. Play the DVD Player.
4. Adjust the volume level using the **VOLUME** knob (12) on the front panel or press the **VOL ▲/▼** button (9) on the remote.

### Note.

The following functions do not work while 6CH-INPUT is selected: input selection, surround mode selection, tone controls, attenuator. To select the input, release the 6CH-INPUT first. The same status prior to the selection of 6CH-INPUT is maintained for the video output. If, for instance, 6CH-INPUT is selected after DVD was selected, the audio system will change to 6CH-INPUT but DVD is maintained for the video output.

## PREPARATIONS FOR RECORDING USING DIGITAL SIGNALS

Select the following settings on the OSD MAIN MENU before using the unit's digital copy function.

1. Press the **AMP** button on the remote control unit to set the remote control unit to the amplifier mode.
2. Press the remote control unit's **<**, **>**, **▲**, **▼** cursor button or the **OK** button.
3. Press the **<** or **>** cursor button to select the **SYSTEM SETUP** item on the OSD MAIN MENU, and press the **OK** button to enter the selection.

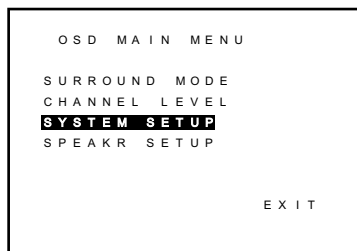

4. Press the **▲** or **▼** cursor button to move to the **DIGITAL OUT** item.

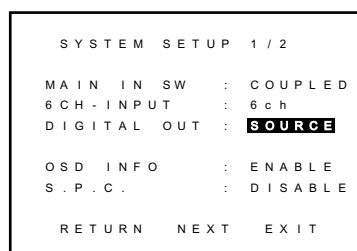

5. Press the **<** or **>** cursor button to select the output status.

- The status changes in the following sequence:

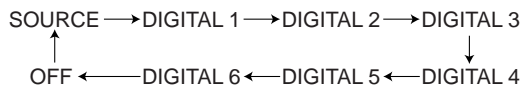

- When **SOURCE** is selected, the input signals from the component selected by the function button are output. The selected input will not be output unless the digital signal input has been set.
  - It is recommended that **OFF** be selected as the setting if no component has been connected to the **DIGITAL OUT** jacks.
6. Press the **OK** button to return to the regular display.

### Example 1:

Digital recording onto an MD from CD:DIG.4 while playing and listening to a DVD using the DVD:DIG.5 input (The digital signals have already been connected as in the connection example.)

1. Press the function button (DVD) to select DVD. In this example, DIG.5 has already been set to DVD.
2. Proceed with the steps for "Preparations for recording using digital signals," and select DIG.4. The COPY indicator now lights.

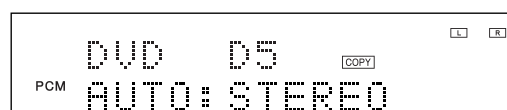
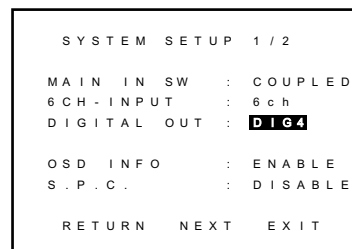

3. Set the digital input for the MD player, and set the player to a recording standby status (such as synchro REC). For further details, refer to the MD player's User Guide.
4. Play the disc in the CD player. Recording now starts.

## OTHER FUNCTIONS

### SETTING THE SLEEP TIMER (ONLY REMOTECONTROL UNIT)

Set the sleep timer while the power is turned on.

1. Turn the power ON and press the **SLEEP** button **[17]** in the AMP MODE.
2. Press the **SLEEP** button **[17]** the number of times to set the desired sleep time. Each press of the **SLEEP** button **[17]** changes the display in the following order:

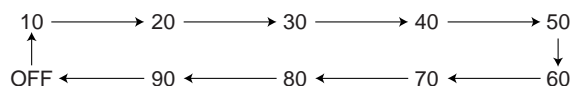

"SLEEP" stops blinking and lights steadily.

While the sleep timer is activated, the remaining time can be displayed for approx. 2 seconds by pressing the **SLEEP** button. To cancel the sleep timer, press the **SLEEP** button **[17]** and then press the **CLEAR** button.



# SURROUND MODES

The PS-17 incorporates digital signal processors (DSP) which can reproduce various surround effects you experience in concert halls and movie theaters, etc. Nine Surround Modes, are provided to reproduce a variety of surround sound effects, according to the content of the source to be played.

Surround mode	FEATURES
<b>AUTO</b>	<p>When this mode is selected, the receiver determines whether the digital input signal is Dolby Digital, PCM-audio or DTS.</p> <p><b>Note:</b> When a Dolby Digital or DTS signal is input, the number of channels for which the corresponding signal is encoded will be played. Inputting a Dolby Digital two channel signal with Dolby surround status automatically subjects that signal to Pro-Logic processing before play. 96 kHz source material can be play back in this mode. Analog input sound is reproduced in stereo. Dolby Virtual surround sound playback is initiated automatically if 5.1-channel signals or Dolby Surround signals are input when the setting does not call for the surround speakers to be used.</p>
<b>DOLBY</b>	<p>With a setting which does not call for the surround speakers to be used, Dolby Virtual surround sound playback is initiated. Using only the front left and right speakers, virtual surround sound playback results to give the impression that surround speakers are present. (Note: The effect will differ depending on the playback source and viewing/listening position.) With a setting which calls for the surround speakers to be used, the Dolby Digital 5.1-channel signal input is played back as is. On the other hand, 2-channel input signals (both analog and digital) are subject to Dolby Pro Logic processing and played back.</p> <p><b>Note:</b> Playback is not initiated for DTS input signals or 96 kHz PCM input signals.</p>
<b>STEREO</b>	<p>This mode bypasses all surround processing. Stereo program sources the left and right channels play normaly when PCM-audio or analog stereo is input. With Dolby Digital and DTS sources, the 5.1 multi-channels are converted to two channel stereo. 96 kHz source material can be play back in stereo mode.</p>
<b>5ch STEREO</b>	<p>This mode is used to create a wider, deeper and more natural soundstage from two channel source material. This is done by feeding the left channel signal to both left front and left surround speaker and the right channel signal to both right front and right surround speaker. Additionally, the center channel reproduces a mix of the right and left channel. The 96 kHz sampling frequency mutes output.</p>
<b>SOURCE-DIRECT</b>	<p>In the source direct mode, the tone control circuite and bass management configuration are bypassed for full range frequeancy responce and the purist audio reproduction. 96 Khz source matirial can be play back in this mode. When analog signal input is selected, the digital unit's processing is stopped to minimize the effects of the high-frequency clock, etc.</p> <p><b>Notes:</b> Internal speaker size is setup to front L/R = Large, Center = Large, Surround L/R = Large and Subwoofer = yes automatically. Tone controls are also defeated.</p>
<b>PURE-DIRECT</b>	<p>In contrast to the SOURCE DIRECT mode, the front panel display circuit is completely shut down, and then the video output circuit is shut down to eliminate superfluous processing in operations other than the audio output. As a result, high-quality music reproduction is achieved.</p>
<b>SRS</b>	<p>The playback mode is selected as follows depending on the input signals and speakers used.</p> <ul style="list-style-type: none"> <li>When the setting calls for the surround speakers to be used: UltraSurround processing is added when multi-channel signals are input. This causes the sound to be reproduced in a wide sound field with improved links between the channels. Circle Surround playback is performed when 2-channel signals are input. In this case, either music mode or cinema mode can be selected. CS CINEMA: This is suited to movie playback. Conventional movies recorded in surround sound will also be played back as 5.1-channel sound. CS MUSIC: This is suited to music playback. Two-channel music sources are converted into 5.1-channel sound for playback.</li> <li>When the setting does not call for the surround speakers to be used: Using only the front speakers, virtual surround sound playback results to give the impression that surround speakers are present. Virtual surround sound playback using TruSurround is performed when multi-channel sound is input. CS Virtual surround sound playback is performed when 2-channel signals are input. In this case, the Circle Surround effect can be enjoyed by the front speakers alone.</li> </ul> <p><b>Note:</b> The effect will differ depending on the playback source and viewing/listening position. The sound of some sources may be played back unnaturally. Playback is not initiated for 96 kHz PCM input signals.</p>
<b>6.1 Surround</b>	<p>This can be used when back surround speakers are used. Unique matrix processing is performed for the surround channels among the 5.1-channel signals to generate back surround channels. This further enhances the sound of the source subjected to Surround EX or DTS-ES processing.</p>

**Caution for DTS signal:**

This signal can be played when the connected DVD-player, laser-disc player or CD-player is capable of DTS-digital output. For details, refer to the player's operation manual.

Depending on the player used, DTS play may produce noise. If that happens, set the Surround mode to DTS.

Playing a DTS-CD or DTS laser disc causes the player's analog output terminal to output noise. Before playing DTS sources, be sure to connect the player's digital output to the PS-17's digital input. Be careful when connecting the output of these players to analog audio input.

Note that the PS-17 has the following restrictive functions built in to reduce noise emission as much as possible.

If DTS is selected while in the Surround mode, digital input cannot be switched to analog input. When the analog input function has been selected, Surround mode cannot be switched to DTS.

While signals from DTS-laser disc or CD are playing in another Surround mode, you cannot switch to digital input or from digital input to analog input.

**Caution for 96kHz PCM-audio signal:**

This signal can be played when a DVD-player or DAT-player connected to the PS-17 is capable of 96 kHz PCM output. For details, refer to the player's operation manual.

The signal can be played when STEREO or AUTO has been selected for the Surround mode.

Some DVD formatted discs featured copy protect. When use such disc, 96 kHz PCM signal is not output from the DVD player. For details, refer to the player's operation manual.

# LISTENING THROUGH HEADPHONES

This unit features a "Dolby Headphone" function.

The Dolby Headphone is ideal for users who do not have the space to install five speakers in their room and for users who want to enjoy movies or music at high volume levels late at night but cannot do so. They were developed to enable users to experience the 3-dimensional acoustics of multi-channel or stereo channel sound while wearing headphones.

## EFFECTS OF DOLBY HEADPHONE

Usually when stereo sound is heard through headphones, the sound is not localized somewhere in front of the listener's eyes as it does with speakers: instead, all the sound is localized inside the listener's head which feels unnatural to the listener.

When sound is heard using the Dolby Headphone function, however, it is heard as if it is being reproduced from the speakers installed in the room.

Normally, the sound delivered by the left speaker is heard in both the listener's left and right ears, and the differences in level, time and characteristics of the sound cause the listener to perceive a directionality. Furthermore, in addition to the direct sound, the indirect sound produced by reflection in the room also reaches the listener's ears.

Listening to sound with headphones means that the listener hears the left sound directly through his or her left ear only so that no sound image is heard in front.

The Dolby Headphone provides virtual room simulation and the resulting acoustic characteristics are overlaid onto, and incorporated into, the left and right headphone signals. For instance, what happens to the left-channel sound mentioned above is that its reverberation components and components of the sound reflected from the room are combined with the left and right speaker (channel) sound and output to the left and right headphones. Since the listener hears in both ears components with the same quality as when listening to sound through speakers, he or she feels as if the sound source were located in front.

This kind of processing necessitates a vast number of complex operations but it has been achieved by improving the performance of the DSP. Whereas stereotypical systems available to date had to optimize the characteristics for each individual listener, the most salient feature of the Dolby Headphone is that they remain essentially unaffected by the listener or type of headphones (even if some small variations exist due to differences in sensitivity and characteristics balance).

The room simulation pattern that provides this effect can be selected from the following three types.

DH1 : The size of a typical living room space is simulated.



DH2 : The expansiveness of a structure as large as a music hall is simulated.

DH3 : A large space such as that found in a movie theater is simulated.

The same bypass (BP) mode as with conventional headphones playback can also be selected.

The following surround sound effects can be selected while the Dolby Headphone function is operating:  
AUTO, DOLBY SURR., SRS, STEREO

## OPERATION

1. Turn the **VOLUME** control knob counterclockwise to the lowest setting.
2. Insert the plug on your headphones into the headphones jack.
3. Select the desired Dolby Headphone's room simulation pattern by pressing the  button on the unit's front panel. Alternatively, it can be selected by pressing the Dolby H button on the remote control unit. Each time the button is pressed, the mode is selected in the following sequence: BP  $\leftrightarrow$  DH1  $\leftrightarrow$  DH2  $\leftrightarrow$  DH3  $\leftrightarrow$  BP.
4. Select the desired surround mode. Press the surround mode button on the unit's front panel or on the remote control unit. AUTO, , SRS or STEREO can be selected.
5. Turn the **VOLUME** control knob clockwise to set the desired volume level.
6. If distortion or other problems arise during LFE signal playback due to inadequate reproduction of the bass which is the case with some headphones, adjust by selecting -10dB or OFF for LFE LEVEL in the SURROUND MODE item on the OSD menu.

### Notes:

The Dolby Headphone function will not work when 96 kHz PCM digital signals are input.

In this case, first supply the analog output signals of the DVD player to the unit, and then activate the Dolby Headphone function. The Dolby Headphone function will not work for 6-channel input signals.

The Dolby Headphone function will not work when SOURCE DIRECT has been selected while the headphones are being used.

Although this function does not require the use of a special pair of headphones, its effect will differ somewhat depending on the type of headphones used.

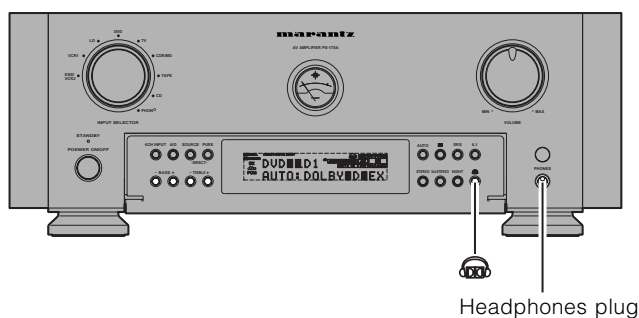



# REMOTE CONTROL UNIT RC-17PS

## NAMES OF BUTTONS & FUNCTIONS

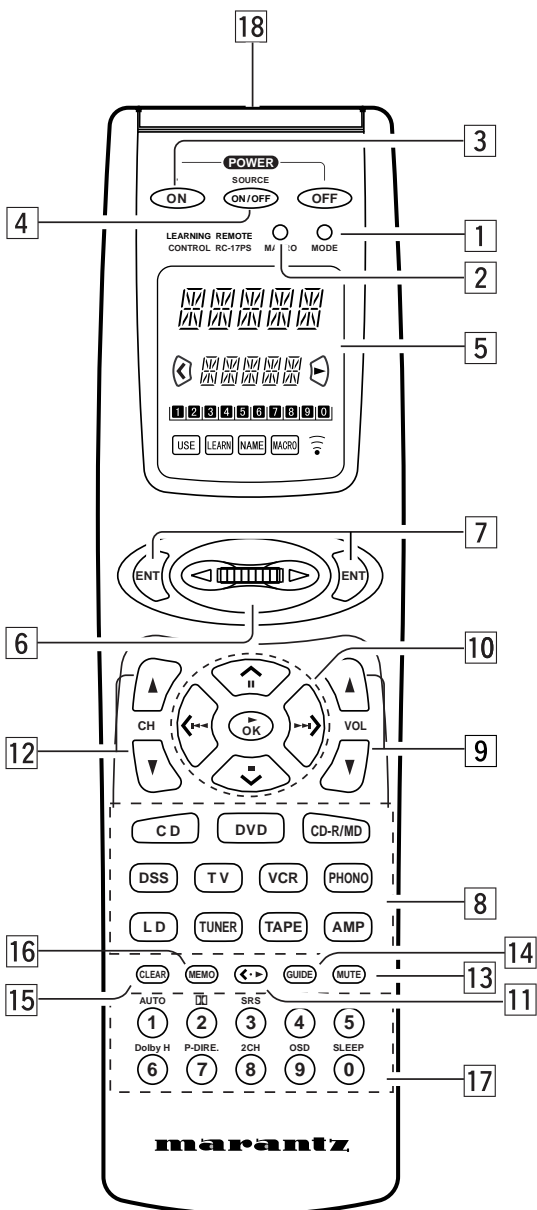

### 1 MODE button

Used to change the operation mode of the remote controller. Pressing this button cycles the remote controller through **USE** fi **LEARN** fi **NAME** fi **USE**, with the currently selected mode displayed on the LCD.

### 2 MACRO button

Used to switch the remote controller in and out of the MACRO mode, which is used to program complex operational sequences (macros), with the currently selected mode displayed on the LCD.

### 3 Power ON and OFF buttons

Used to turn the main system component (usually a amplifier) ON and OFF.

### 4 Source ON/OFF button

Used to turn specific sources (such as DVD players, etc.) ON and OFF independently from the rest of the system.

### 5 LCD

Used to display information about currently selected modes and functions.

### 6 Jog Dial

Used to select the operation content for each source. 10 types of direct operation are possible for each of the 11 functions including LD, TV, AMP, etc. After selecting the desired function, press either of the **ENT** button **7** to transmit the signal.

### 7 ENT buttons

Used to execute a function selected with the **Jog Dial** **6**. There are 2 enter buttons, one on each side, so that the remote controller can be used just as easily with either hand. The characters on the display can also be programmed.

Function	Jog Dial command	Note
AMP	1 MODE	selects surround mode
	2 A/D	switches analog/digital input
	3 ATT	switches attenuator for analog input
	4 NIGHT	selects NIGHT mode for Dolby Digital
	5 MULTI	activates multi-room mode
	6 6-DIR	activates 6-channel setup
	7 TRB+	increases treble
	8 TRB-	decreases treble
	9 BAS+	increases bass
	0 BAS-	decreases bass

### 8 Function buttons

Used to switch the remote controller to the command sets for specific sources (amplifier, receiver, etc.), thereby allowing a single remote controller to control up to 11 different components. To use these buttons to switch the amplifier's source, press the desired button twice within 2 seconds. The **AMP** button **8** is used only to switch command set of the remote controller itself and therefore does not transmit any signal. Further, the function buttons may also be programmed to execute macros. (A macro allows a complex string of operations to be performed in series simply by pressing a single button.) One button can be programmed to learn sequences containing up to 10 commands. The following is an example of such a sequence that can be activated automatically using a macro: Turn the amplifier ON fi Switch the function to DVD fi Set the Surround Mode to Dolby Digital fi Switch the TV to video input fi Set the DVD player to Play.

**9 VOLUME ▲ up / ▼ down buttons**

Used to adjust the volume on amplifier and other components equipped with volume control.

**10 CURSOR/TRANSPORT CONTROL buttons**

Used to operate on-screen and other displays used by amplifier and other components, as well as to operate the PLAY, STOP, PAUSE, NEXT, and PREVIOUS functions of each source.

**11 <•▶ (CURSOR/ TRANSPORT CONTROL switching) button**

Used to switch the function of the CURSOR/ TRANSPORT CONTROL buttons 10 between the CURSOR and TRANSPORT CONTROL functions, with the currently selected function displayed on the LCD when the DVD, LD, or VCR functions are selected. When functions other than DVD, LD, or VCR are selected, the <•▶ button remains inactive.

**12 Channel ▲ up / ▼ down buttons**

Used to controls the up/down function of tuner, or to cycle through the tuner presets.

**13 MUTE button**

Used to temporarily mute the sound for preamplifiers, receivers, etc.

**14 GUIDE button**

Used to call up the on-screen menus used to control DVD players, digital satellite systems (DSS), and other menu-equipped systems.

**15 CLEAR button**

Used to clear the contents of memory or programmed functions.

**16 MEMO button**

Used to program your CD player's track memory, or to enter a VCR recording program, and can be used to provide the MEMO function included with other components in your system.

**17 Ten-Key pad/Surround Mode buttons**

Used to enter numeric digits, useful for finding a specific track on a CD or DVD, etc. When the function is set to AMP, it is possible to choose Surround Mode, etc.

**18 Infrared Transmitter/Receiver Window**

Used to transmit remote control signals based on beams of infrared light to system components. To ensure that these signals are properly received, make sure that this window is pointing in the general direction of the infrared receiver on the amplifier or other components. This window should also be pointed toward the source remote controller when using Programmable Learning function.

**Note:**

The **MODE** 1, **MACRO** 2, **Jog Dial** 6 and <•▶ (CURSOR/ TRANSPORT CONTROL switching) 11 cannot be programmed.

**LCD (Liquid Crystal Display)**

Information about currently selected functions and modes is displayed on the LCD. Pressing any buttons will call up a full display of information on the status of that function or mode. This display will disappear after approximately 1 minute, except for the **Function Name** indicator @, which is always displayed.

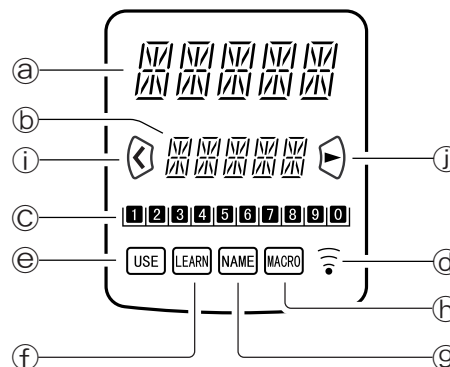
**@ Function Name indicator**

Displays the name of the currently selected function (LD, TV, etc.) using up to 5 characters.

**(b) Command Name indicator**

Displays up to 10 types of commands for each function using up to 5 characters.

**(c) Command Page indicator**

Allows confirmation of current command page. Also, when setting or transmitting macros, displays information such as the number of macro steps and the time intervals between command transmissions.

**(d) Transmission indicator**

Indicates when the remote controller is transmitting a signal.

**(e) USE indicator**

For normal operation the USE indicator is displayed.

**(f) LEARN indicator**

Indicates when the remote controller is in the LEARN mode.

**(g) NAME indicator**

Indicates when the remote controller is in the NAME mode and a function name is being changed.

**(h) MACRO indicator**

Indicates when the remote controller is in the MACRO mode.

**(i) CURSOR indicator**

Indicates when the CURSOR/TRANSPORT CONTROL button is in the cursor mode.

**(j) CONTROL indicator**

Indicates when the <•▶ (CURSOR/TRANSPORT CONTROL switching) 11 is in a transport control mode such as PLAY, STOP, etc.

- If the LCD flickers when a button is pressed in order to transmit a command or when in the LEARN mode, the transmission or learning is not possible. In such a case, please replace the batteries.
- This remote controller uses non-volatile memory, so that learned codes and macros will be preserved even if the batteries are removed.



## OPERATION OF REMOTE CONTROL UNIT

### 1. Remote control

The distance between the transmitter of the remote control unit and the IR SENSOR of the PS-17 should be less than about 5 meters. If the transmitter is pointed to a direction other than the IR SENSOR or if there is an obstacle between them, remote control may not be possible.

#### Remote-controllable range

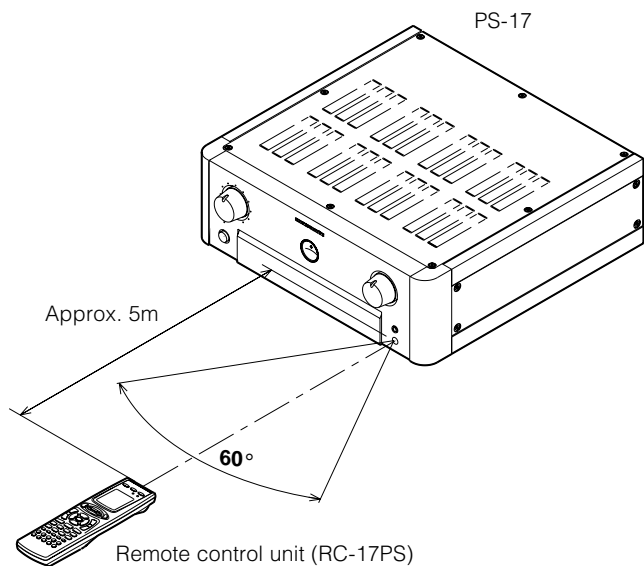

### 2. Loading batteries

The life of the batteries used with the remote control unit is about 6 months with normal use. Also be sure to replace batteries earlier when you notice that they are getting weak.

#### (1) Remove the back cover.

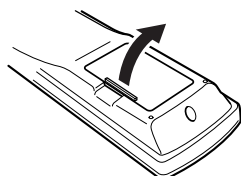

#### (2) Insert the new batteries (AA type) with correct (+) and (-) polarity.

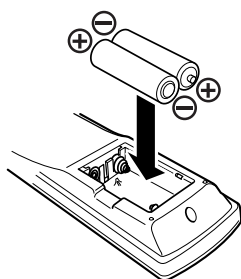

#### (3) Close until it clicks.

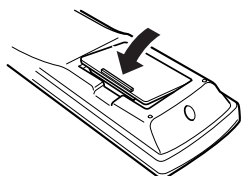

## BASIC OPERATION

### USE MODE

The remote controller will normally be used in the USE mode. It comes preset with codes commonly used to control 11 types of components manufactured by Marantz and Philips, including DSS, DVD, TV, LD, VCR, TUNER, CD, TAPE, CD-R/MD, and AMP, as well as many others that utilize the RC-5 remote control language.

1. Press once one of the **Function** buttons [8] to change to another component's commands, such as LD button.

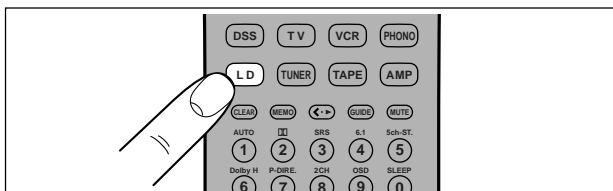

2. **LD** will be displayed on the LCD and the function codes will be set to operate the laser disc player, and if you double clicked the LD function button, the preamplifier input will be changed as well.
3. Now you can operate the laser disc player. When a button is pressed, the symbol indicates that a remote code is being transmitted. is not displayed if a button for which no code has been set is pressed.
4. The **Jog Dial** [6] is used to select any one of up to 10 direct operations that can be performed for each of the 11 functions (LD, TV, AMP, etc.). Rotate the **Jog Dial** [6] to select one of these commands. The number of the current page is indicated by **1-0**.

Page numbers cycle up or down, for example **8** fi **9** fi **0** fi **1** fi etc. or **3** fi **2** fi **1** fi **0** fi etc. depending on which way the **Jog Dial** [6] is rotated then press **OK** [10] button.

The last page position for any given command function is retained in the memory even if the remote controller is switched to the command function for another component. (Last Memory)  
If it is left for approximately 1 minute without pressing any buttons, all items on the LCD will go off except the function indicator.

Even if the display goes off, the remote controller will hold the page position and other data. The display may be activated again by pressing any button.

### LEARN MODE

The remote controller is capable of learning and memorizing the remote control codes used by almost any other remote controller you may already own.

- If no commands have been programmed for a particular function button, the remote controller will transmit whatever codes have been factory preset.
- The following example shows how to program your remote controller and how to use the codes for a laser disc player (LD).
- The remote controller infrared receiver is located at the top of the remotecontroller.

1. Use a ballpoint pen or other sharp point to press the **MODE** button [1] until the **LEARN** indicator is displayed. Each time you press this button, the mode will cycle through **LEARN** fi **NAME** fi **USE**.

Stop when the **LEARN** indicator starts to blink.

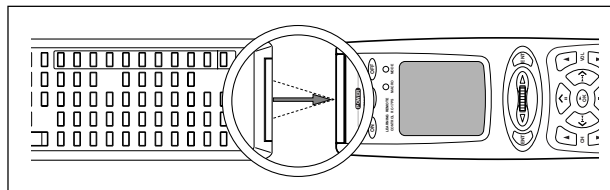

2. Place the laser disc's remote controller so that its infrared signal transmitter is facing the infrared signal receiver on the Marantz remote controller at a distance of about 5 centimeters (2 inches).

3. Press the **LD Function** button ,.

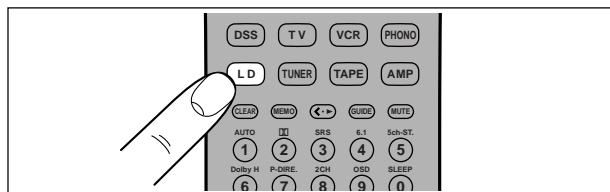

4. Press the **PLAY** button [10] (▶ **OK**). The **LEARN** indicator changes from blinking to continuously lit.

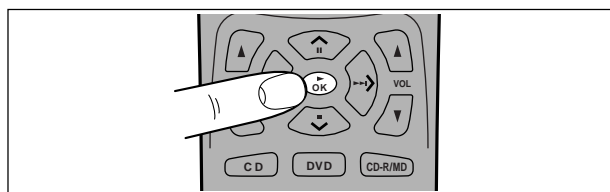

5. Press and hold the **PLAY** button on the laser disc player's remote controller. The remote controller has finished learning the command when **OK** appears on the LCD @.

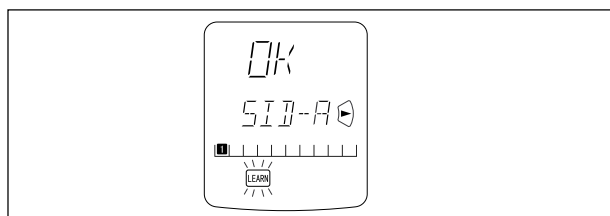

- If **AGAIN** appears on the LCD, some error has prevented the command from being learned. If this happens, simply repeat the procedure from step 4.
  - In the rare event that **NG** appears on the LCD, it means that the remote controller you are attempting to learn from uses special signals that cannot be learned by the Marantz remote controller.
6. Follow the same procedure to make the remote controller learn the ten-key [17] operation used by the laser disc player's remote controller.

7. Repeat the procedure from step 3 to have the remote controller learn the signal codes for the other components such as TV, VCR, etc.
  - If no buttons are pressed for approximately 1 minute while in the LEARN mode, the remote controller automatically returns to the USE mode.
  - When programming the function buttons, first switch to the desired function, then press the button again.
8. When you have finished programming the remote controller, use a ballpoint pen or other sharp point to once again press the **MODE** button [1] to return it to the USE mode. The LCD displays the **USE** indicator, and the newly programmed codes now can be used.

#### If FULL is displayed on the LCD

If **FULL** is displayed on the LCD [D] when programming in the LEARN mode, it means that the memory has become too full to hold any further codes.

If **FULL** is displayed no matter how many times you attempt to enter new codes, it means that the remote controller cannot accept any new codes until some of the previously learned codes are deleted to make space in the memory. Select unneeded codes for each of the **Jog Dial** control [6] and **Function** buttons [8] which show **FULL** and delete them from the memory.

#### Note:

The power **ON** and **OFF** buttons [3] can only be programmed to learn one type of code, regardless of the function button that has been selected.

## PROGRAMMING THE JOG DIAL

Let's use the example of setting [2] as the SIDE-B code for the laser disc player.

1. Use a ballpoint pen or other sharp point to press the **MODE** button [1] until the **LEARN** indicator is displayed and starts to blink.
2. Place the laser disc's remote controller so that its infrared transmitter window is facing the infrared signal receiver window on the Marantz remote controller at a distance of about 5 centimeters (2 inches).
3. Press the **LD Function** button [8].
4. Rotate the **Jog Dial** [6] left or right until [2] is displayed, then press the **ENT** button [7].
  - The **LEARN** and **NAME** indicators will both be displayed.

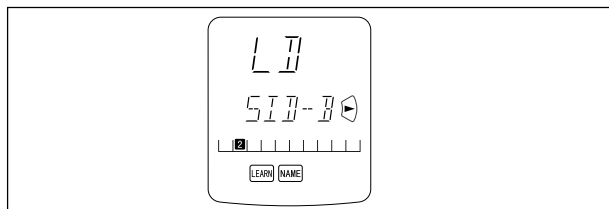

5. Press the **SIDE-B** button on the laser disc's remote controller continuously until **OK** is displayed on the Marantz remote controller's LCD, indicating that the programming has been completed.
  - If **AGAIN** appears on the LCD, some error has prevented the command from being learned. If this happens, simply repeat the procedure from step 4. When the programming has been completed, the remote controller automatically switches to the NAME mode. The left hand position on the LCD [D] blinks, indicating the character in the name to be rewritten.

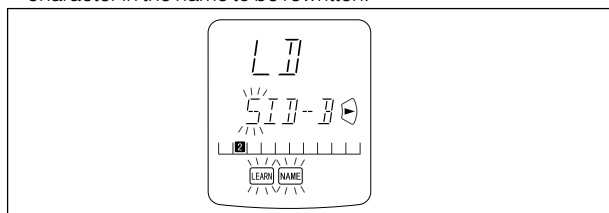

- If you do not wish to rewrite the name, simply press the **OK** Cursor button [10].
  - If you wish to rewrite the name, input the desired characters using the ten-key pad [17]. The part of the display that is being rewritten may be selected using the < and > Cursor buttons [10]. When you are finished rewriting, press the **OK** Cursor button [10]. To simply erase already existing characters, press the 0 button to replace them with a blank space. (Refer to next section on rewriting names)
6. Use the same procedure to program the codes for other 1-6 with the **Jog Dial** [6].
  7. When finished programming the codes for each of the buttons, use a ballpoint pen or other sharp point to press the **MODE** button [1] to return the remote controller to the USE mode. Once **USE** is displayed on the LCD, the newly memorized codes are available for use.

### REWRITING NAMES

This remote controller allows the names accessible by **Jog Dial** control [6] to be rewritten with new ones of your choosing.

- Rewriting of names is performed for each individual function.
- Let's use a laser disc player as an example to show how to change the "LD" to "SIDE-A" to "LD-A".

1. Use a ballpoint pen or other sharp point to press the **MODE** button [1] to switch the remote controller to the NAME mode. The **NAME** indicator blinks.
2. Press the **LD Function** button [8].

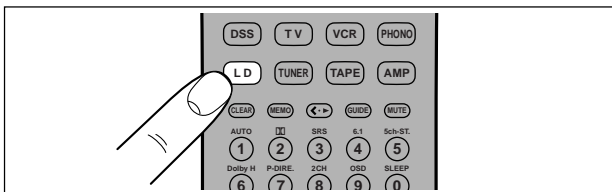

3. Use the **Jog Dial** [6] to select the page for which you wish to enter a new name.
4. The character on the left-hand side of the Command Name indicator on LCD [6] will flash, indicating that it is the character ready to be rewritten. New characters entered will be written over the top of the current character so that the current character is erased. Use the < and > Cursor buttons [10] to select the characters to be rewritten.

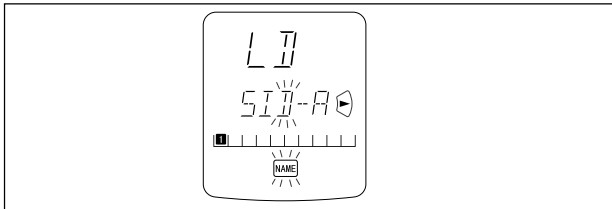

5. Use the ten-key pad [17] to select the desired alphanumeric characters. Pressing the number buttons on the ten-key pad will cycle through the alphanumeric characters as follows:

Ten keypad	Press, press again, press again, etc.
1	A fi B fi C fi 1 fi A
2	D fi E fi F fi 2 fi D
3	G fi H fi I fi 3 fi G
4	J fi K fi L fi 4 fi J
5	M fi N fi O fi 5 fi M
6	P fi Q fi R fi 6 fi P
7	S fi T fi U fi 7 fi S
8	V fi W fi X fi 8 fi V
9	Y fi Z fi / fi 9 fi Y
0	SPACE fi + fi - fi , fi ' fi 0 fi SPACE ( )

6. Therefore, to enter the letter "L", press the 4-key on the ten-key pad [17] 3 times in a row to cycle from J to K to L.

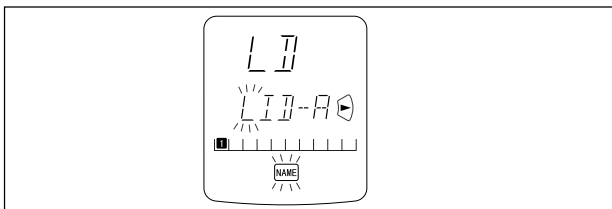

Once the desired character "L" appears, press either of the < and > Cursor buttons [10] and the L will be permanently written over the former character. Press the 0-key in order to replace unneeded extra characters with spaces.

7. Follow the same procedure to enter "D-A". When finished, press the **OK** Cursor button [10]. Pressing **OK** permanently fixes the newly written characters.

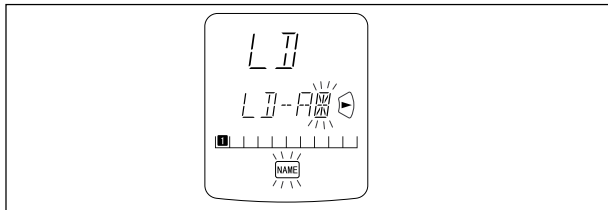

- Up to 5 alphanumeric characters may be entered in the Command Name indicator of the LCD.
  - To rewrite the names of the other items in the Command Name indicator, use the **Jog Dial** [6] to select the desired command and repeat from step 5.
8. When you are finished rewriting, use a ballpoint pen or other sharp point to press the **MODE** button [1] to return the remote controller to the USE mode. The **USE** indicator is displayed on the LCD, and the newly programmed codes now can be used.

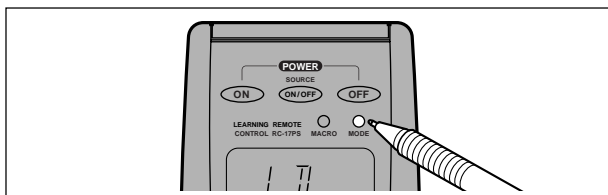

### ERASING PROGRAMMED CODES

#### (Returning to Factory Presets)

Codes that have been programmed into the memory can be erased in 3 ways: by button(s), by function(s), and by Jog Dial command.

1. Use a ballpoint pen or other sharp point to press the **MODE** button [1] to switch the remote controller to the LEARN mode, so that the **LEARN** indicator is blinking on the LCD.

#### Note:

Erasing of programmed codes is only possible in the LEARN mode.

2. **Erasing by Button(s)**

To erase the codes and names programmed for any button, press and hold the **CLEAR** button [15], then press the button to be erased twice. This will return the button to its factory presets or leave it empty if no factory presets are available.

Jog Dial codes may be erased in the same way, by pressing and holding the **CLEAR** button [15] while using the **Jog Dial** [6] to call up the command to be erased, then pressing one of the **ENT** buttons [7] on either side of the **Jog Dial** [6] twice. This will return the button to its factory presets or leave it empty if no factory presets are available.

To erase codes programmed for the **CLEAR** button [15], simply press the **CLEAR** button [15] continuously for 3 seconds.

As an example, let's clear the PLAY command from the laser disc player command set.

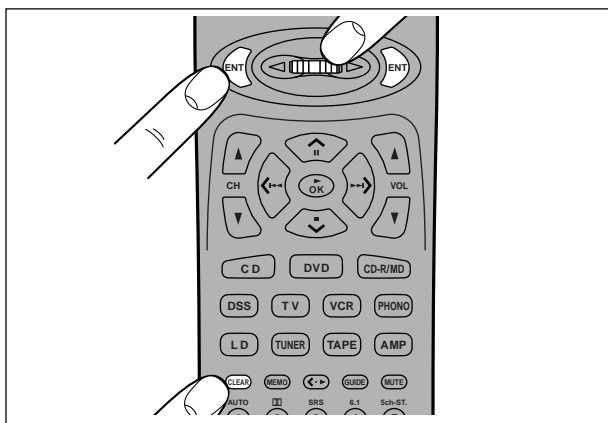

### 3. Erasing Jog Dial Codes

To clear all codes and names previously set for each of the functions (LD, TV, etc.).

- 1) Press the function you want to erase.
- 2) Hold down the **CLEAR** button **15** and press both **ENT** buttons **7** at the same time. LCD **ⓐ** will display **CLR?**.

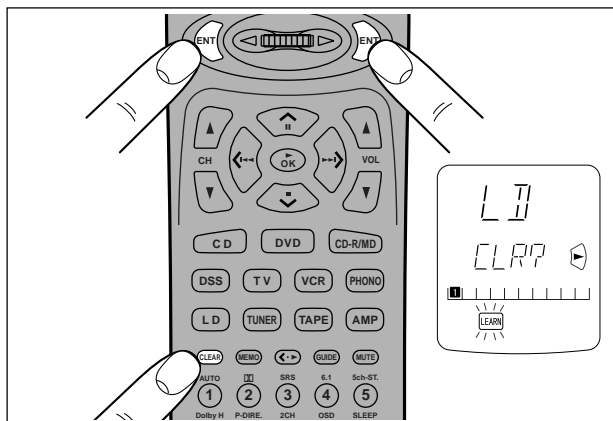

- 3) If you wish to continue the clearing operation, press the **OK** Cursor button **10**. This will return all 10 commands in the Jog Dial to their factory presets, or leave them empty if no factory-presets are available. Accordingly, the LCD **ⓐ** will return to the factory preset displays, or will simply be empty.

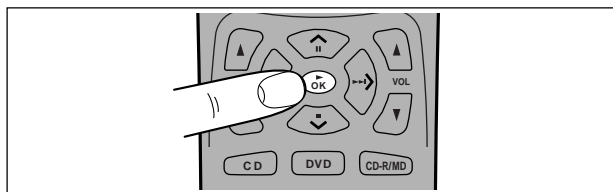

- Use a similar operation to erase the Jog Dial codes for each function.
- To cancel the memory clearing operation, do not press **OK** Cursor button **10** and simply touch any other button.

### 4. Erasing Codes by Function

To clear all codes and names previously set for each of the functions (LD, TV, etc.), press and hold the **CLEAR** button **15**, then press the button for the function to be cleared twice. **CLR?** will appear on LCD **ⓐ**. If you wish to continue the clearing operation, press the **OK** Cursor button **10**.

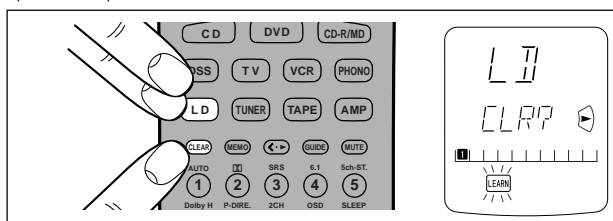

This will return the button to its factory-presets or leave it empty if no factory presets are available. Accordingly, the LCD **ⓐ** will return to the factory preset displays, or will simply be empty.

- To cancel the memory clearing operation, do not press the **OK** Cursor button **10** and simply touch any other button.
- The codes for the **<•>** button **11** cannot be cleared.

### PROGRAMMING MACROS

Macros make it possible to use a single function button to perform more complex series of operations that would normally require pressing several buttons. A single button can be programmed to perform up to 10 steps in sequence. A typical example of such a series might be as follows:

- Turn the main amplifier power ON **fi** Switch the function to LD **fi** Set the Surround Mode to Pro Logic **fi** Switch the TV to video input **fi** Set the laser disc player to PLAY.
- No signals may be transmitted during macro programming.
- The various steps that make up a macro are set initially to be sent one after another in 1 second intervals, however these intervals may be shortened to as little as 0.5 seconds or lengthened to as much as 5 seconds using the Setup mode.
- In the macro mode, the number of steps the macro contains is displayed on LCD **ⓐ**. Macros may be programmed for each of the 11 function buttons, from LD to AMP.

1. Use a ballpoint pen or other sharp point to press the **MACRO** button **2** until the **MACRO** and **LEARN** indicators are displayed blinking on the LCD.

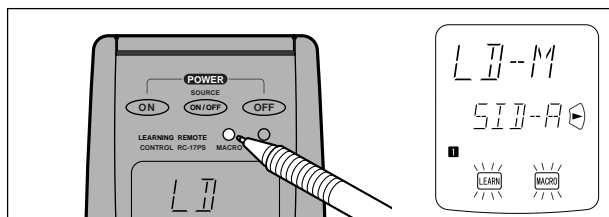

2. Press the **Function** button **8** for which you wish to program a series of operations. In this case, let's use the example of the laser disc player.

Press the **LD Function** button **8**. The LCD **ⓐ** will display LD-M. Characters displayed on LCD **ⓐ** include the following, depending on the function button for which the macro is being programmed:

LD-M, DVD-M, TV-M, DSS-M, VCR-M, AUX-M, TUN-M, CD-M, TP-M, AMP-M, CDR-M (or MD-M for remote controller set for MD).

- If a macro has already been set for the selected function button, the LCD **ⓐ** will blink. Also, the number of steps in the macro is displayed on LCD **ⓐ**.

- Press the buttons for the operations you wish to program as a macro in the sequence you want the macro to program them. The name of the button pressed appears on LCD **@**. The number of steps in the macro is displayed on LCD **©** and this number increases by 1 with each button pressed.

For example, press LD, PLAY.

Each function button can be programmed to perform up to 10 steps in sequence.

- If, while programming, no buttons are pressed for approximately 1 minute, the remote controller will automatically return to normal mode, and no macro will be programmed in the memory.

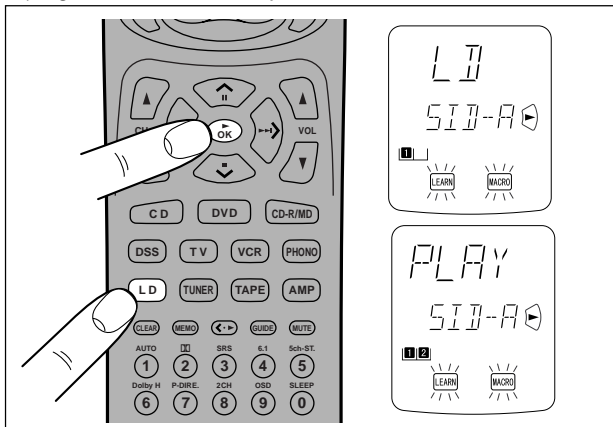

- When you are finished programming macros, use a ballpoint pen or other sharp point to press the **MACRO** button **[2]**. LCD **@** will display **END**, and the display will return to normal.

- Macros cannot be programmed for the **MODE** **[1]**, **MACRO** **[2]**, **←▶** **[11]**, **VOL ▲/▼** **[9]**, **MEMO** **[16]** or **CLEAR** **[15]** buttons.

In the macro mode it is possible to program the memory to perform macros containing up to 10 steps.

Each of the function operations (11 including CD, DVD, etc.) can be used in a macro more than once, however for all except AMP, only the first function operation will be transmitted as a signal from the remote controller. Accordingly, within a single macro, it is not possible to switch between multiple function operations. (This is to prevent the switching of the receiver function operation.) Within a macro, the second time a function operation is used, it will only be used on the remote controller itself and no signal will be transmitted to the component.

- While pressing the **VOL ▲** button **[9]**, use the **^** and **v** Cursor buttons **[10]** to call up the portion of the macro to be changed. Pressing the **^** button advances through the macro steps and pressing the **v** button regresses through the macro steps.

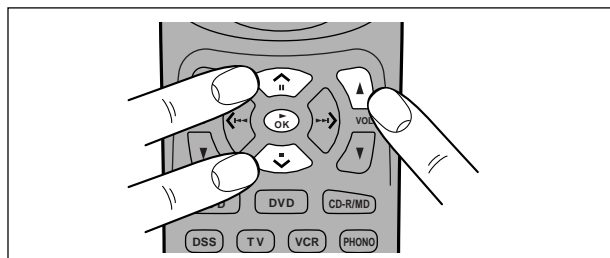

- To rewrite an existing macro step, simply press the button for the new step. The old step will be erased and rewritten with the new step.
- To insert a new step in between existing steps in a macro, after step 3 press the **MEMO** button **[16]**, then press the button for the new step. The numbers of the other steps will be adjusted accordingly to accommodate the new step. Since only 10 steps may be stored in any macro, the tenth step will be erased if an step is inserted when the total number of steps is already 10.

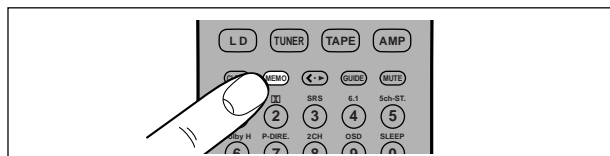

- To erase a step in a macro, after step 3 call up the number of the step to be erased and press the **CLEAR** button **[15]**.

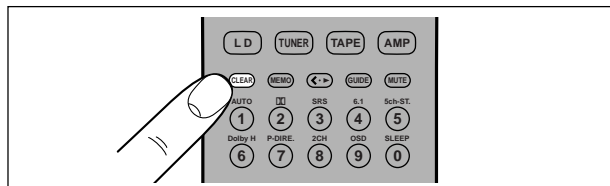

- If while editing macros no buttons are pressed for approximately 1 minute, the remote controller will automatically return to normal mode, and no macro changes will be programmed in the memory.
- When you are finished editing macros, use a ballpoint pen or other sharp point to press the **MACRO** button **[2]**. **END** will be displayed on LCD **@** and the display will return to normal.

## EDITING MACROS

Macros may be edited using following procedure.

- Use a ballpoint pen or other sharp point to press the **MACRO** button **[2]** until the **MACRO** and **LEARN** indicators are displayed blinking on the LCD.
- Press the **Function** button **[8]** to be changed. Let's use the example of the laser disc player, by pressing the **LD Function** button **[8]**.
  - LD-M** is displayed blinking on LCD **@**.
  - The number of steps in the completed macro is highlighted on LCD **©**. In this example there are 3 macro programs in memory.

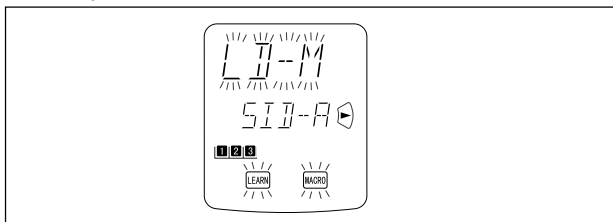

The **1** is highlighted if no macros have been programmed, and the remote controller is ready for macro programming.

## USING MACROS

The following procedure will show how to use the function buttons for which you have programmed macros.

- Press the **Function** button **[8]** for the desired macro for 3 seconds. **MACRO** is displayed on LCD **@** for approximately 1 second, after which the number of steps in the macro is displayed on LCD **©**.

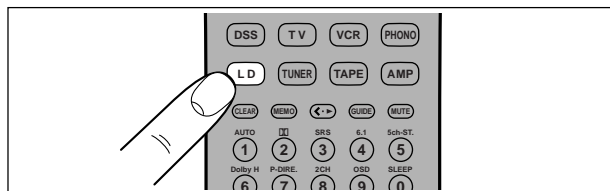

- The remote controller will do nothing if no macros are programmed. The macro steps are executed in order and the names of their buttons are displayed on the LCD. Also, the step numbers displayed on LCD **©** disappear as each step is executed.
- After all macro commands have been transmitted, the remote controller returns to normal mode.
    - To cancel the transmission of a programmed macro, use the Cursor buttons **[10]** to press **■**.

**EXAMPLES OF MACRO PROGRAMS**

**Example 1**

Change the input source for the amplifier to CD and play the 3rd track on a CD in the CD player.

1. Use a ballpoint pen or other sharp point to press the **MACRO** button [2], then press the **CD Function** button [8]. CD-M is displayed on the LCD.

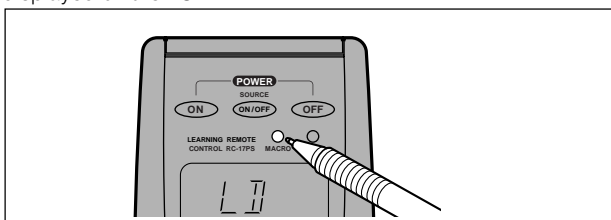

2. Press **CD** [8], **3** [17], and **▶** [10] buttons.

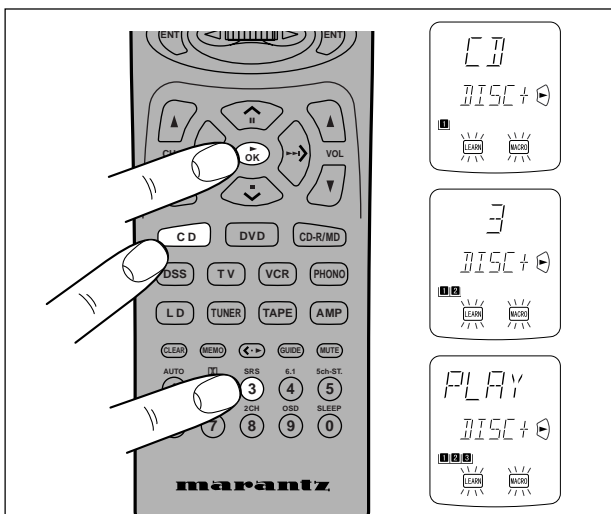

When you are finished programming the macro, use a ballpoint pen or other sharp point to press the **MACRO** button [2].

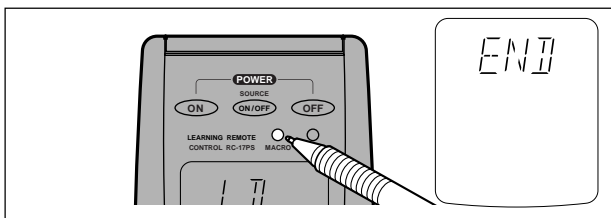

**Now, execute the macro you just programmed.**

1. Press the **CD Function** button [8] for 3 seconds.



2. The macro commands are transmitted to the components in order, and the names of the operations being performed are displayed on the LCD in order.

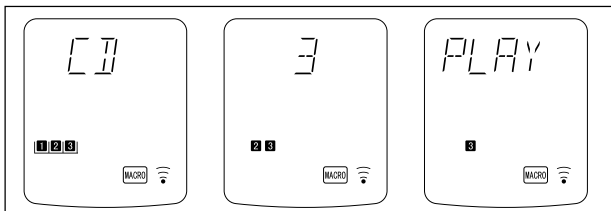

**Example 2**

Turn the main amplifier ON. Change the amplifier's input source to LD. Set the Surround mode to DOLBY. Switch the TV to video input. Set the laser disc player to PLAY.

1. Use a ballpoint pen or other sharp point to press the **MACRO** button [2].

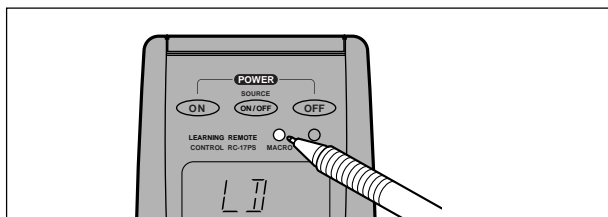

2. Press the **LD Function** button [8].
  - Here the **LD Function** button [8] is used as the macro button, but any function button can in fact be used.
3. To set the various steps of the macro, press the following buttons in order: **POWER ON** [3], **LD** [8], **AMP\*** [8], **2 (DOLBY)** [17], **TV\*** [8], **VIDEO** (use **Jog Dial** [6] to select VIDEO and press **ENT** button [7]), **LD\*** [8], **▶** [10].
4. When you are finished programming the macro, use a ballpoint pen or other sharp point to press the **MACRO** button [2]. The remote controller returns to normal mode.

**Now, execute the macro you just programmed.**

1. Press the **LD Function** button [8] for 3 seconds. The macro commands are transmitted in order, and the names of the operations being performed are displayed on LCD @ in order.

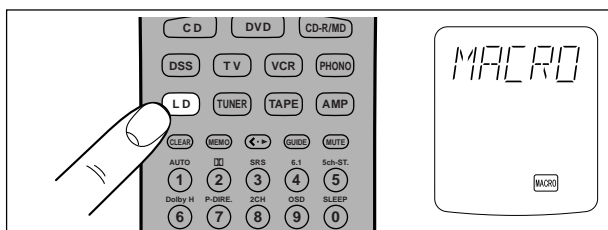

- When executing this macro, function operations AMP\*, TV\*, and LD\* only switch the command set of the remote controller and no signal is transmitted to the component.
- To cancel the transmission of a programmed macro, use the **Cursor** buttons [10] to press ■.

**CLEARING MACRO PROGRAMS**

The following procedure is used to erase macros you have programmed into the remote controller's memory.

1. Press and hold the **CLEAR** button [15], then the button for the function [8] to be cleared (in this case LD) for 3 seconds. **LDCL?** will appear on LCD @. If you wish to continue the clearing operation, press the **OK** Cursor button [10].

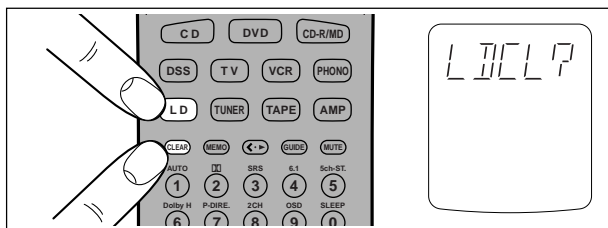

- To cancel the memory clearing operation, do not press **OK** Cursor button [10] and simply touch any other button.

## OTHER FUNCTIONS

### LUMINOUS BUTTONS

The buttons on this remote controller are designed to remain luminous in dim lighting conditions. If the buttons are no longer luminous when the remote controller is used in low light, recharge them by placing it near a fluorescent or other light source for a sufficient amount of time. This should return the buttons to their luminous condition.

### SETUP

Switch the RC-5 destination or adjust the time interval between transmissions of macro operations as follows:

1. While pressing the **MEMO** button [16], press the **OK** Cursor button [10]. This will switch the remote controller to the Setup mode.

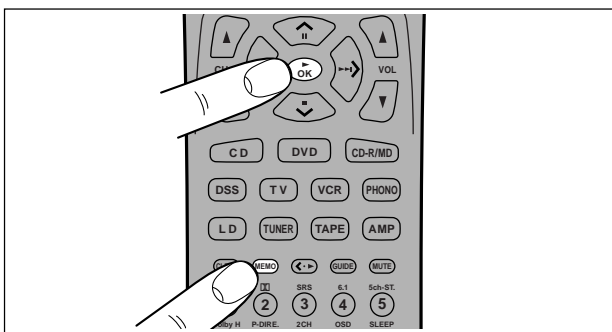

The Setup mode includes the following items, which may be accessed using the  $\wedge$  and  $\vee$  Cursor buttons [10].

- Switch destination (version) (VER)
- Adjust time interval between transmissions of macro operations (MACRO)

### VER: Switches the type of preset codes contained in the remote controller.

LCD (a) displays **VER**, while LCD (b) displays either **USA** or **REST**. **USA** means that the **CD-R/MD Function** button [8] is set to CD-R. **REST** means that the **CD-R/MD Function** button [8] is set to MD.

Use the  $\leftarrow$  and  $\rightarrow$  Cursor buttons [10] to select the desired version, then press the **OK** Cursor button [10]. This will finish the operation and return the LCD to its original state.

- To cancel the setting, press any button other than the Cursor buttons [10].
- To continue the setting, press the  $\vee$  Cursor button [10].

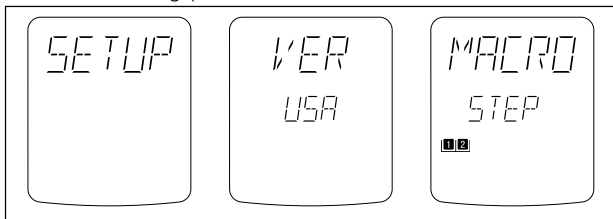

### Note:

Codes that have been programmed will not be erased even if the VER setting is changed, however the **NAME** indicator displays associated with the Jog Dial command will be changed. Also, the Jog Dial commands for CD-R/MD functions that are contained within macros will also change.

### MACRO: Adjusts the time interval between transmissions of macro operations

When the  $\vee$  Cursor button [10] is pressed, LCD (a) displays **MACRO**, while LCD (b) displays **STEP**.

One square (■) in LCD (c) is equivalent to an interval of 0.5 seconds, allowing intervals of up to 5 seconds to be set. The remote controller is set at the factory with an interval of 1 second, as indicated by (■■■■■■■■■■). Adjust the interval between transmission of operation codes using the  $\wedge$  and  $\vee$  Cursor buttons [10], then press the **OK** Cursor button [10].

- To cancel the setting, press any button other than the Cursor button [10].
- To continue the setting, press the  $\vee$  Cursor buttons [10].

## BATTERY LIFE

- New batteries will last about 6 months assuming an average of 30 uses per day.

### Note:

The batteries shipped with the remote controller are for the purpose of checking function and may not last as long as new batteries.

## NUMBER OF LEARNABLE CODES

The remote controller (RC-17PS) uses 128-Kbyte large-capacity non-volatile memory (EEPROM) and is therefore capable of learning a maximum of 330 remote control codes. This applies only to Philips RC-5 remote programming language codes, however, and depending on the type of other codes that are programmed, the remote controller can learn less than 330 codes.



## JOG DIAL COMMAND FUNCTIONS LISTING

Each of the 10 Jog Dial commands on the LCD has 5 character labels attached for pre-programmed remote commands. These commands can be used with various Marantz A/V components, or other components using the Philips RC-5 remote control language.

You can easily replace the factory-supplied remote command codes with different codes from other brands of component. Most of the supplied functions apply to a wide variety of component from many companies. The following list shows the remote code assignments for the Jog Dial commands, for each of the 11 Function buttons, as supplied from the factory. You can add or replace Jog Dial commands, including re-naming them if you wish, in order to customize the remote controller for your own particular selection of A/V components.

Function	Jog Dial command	Note
AMP	1 MODE 2 A/D 3 ATT 4 NIGHT 5 MULTI 6 6-DIR 7 TRB+ 8 TRB- 9 BAS+ 0 BAS-	selects surround mode switches analog/digital input switches attenuator for analog input selects NIGHT mode for Dolby Digital activates multi-room mode activates 6-channel setup increases treble decreases treble increases bass decreases bass
TUNER	1 FM 2 AM 3 LW 4 T-MOD 5 SCAN 6 STM 7 AF 8 PTY 9 DISP 0 DWR	FM band AM/MW band Long Wave band mono/stereo/muting mode selector programmed preset channel scan selects station mode selects AF function selects PTY function selects display function selects DSR wave range
TV	1 A/CH 2 100S 3 VIDEO 4 INFO 5 S-PIC 6 S-SUD 7 S-CH 8 ADV 9 OSD 0 MENU	alternate channel 100's selects video information smart picture smart sound smart channel advance activates on-screen display menu
CD	1 DISC+ 2 DISC- 3 TEXT 4 SHUFL 5 REPT 6 TRAY 7 AMS 8 TIME 9 FF 0 REW	CD changer next disc CD changer previous disc activates text function shuffle play function repeat function tray open/close automatic music scan time display elapsed/remaining/total fast forward rewind
LD	1 SID-A 2 SID-B 3 DISP 4 AMS 5 AUDIO 6 RPT-A 7 RPT-B 8 CP/F 9 EDIT 0 D/CX	side A side B display on/off automatic music scan selects audio mode repeat A start point repeat B stop point selects chapter or frame activates edit function selects digital audio/analog audio/CX NR
TAPE	1 TP-A 2 TP-B 3 DIR 4 TIME 5 TRAY 6 AMS 7 REC 8 PAUSE 9 0	selects tape deck A selects tape deck B auto reverse direction time display tray open/close automatic music scan record pause

Function	Jog Dial command	Note
VCR	1 REC 2 SELECT 3 2XPLY 4 LOW 5 STIL 6 OTR 7 AUDIO 8 SKIP 9 VIS+ 0 VIS-	record selects TV or VCR twice normal playback speed slower than normal playback speed still frame one touch recording audio track selector skip to next program marker VHS index search next VHS index search previous
DSS	1 DISP 2 PREV 3 SELECT 4 AUDIO 5 FAV 6 ALT 7 FTCH 8 ANT 9 REC 0 OTR	brings up on-screen channel marker goes to previously selected channel selects TV or VCR audio track selector favorite users and channel lists alternate audio channel, languages brings up on-screen channel logos select broadcast or cable antenna record one touch recording
PHONO	1 PHONO 2 PHONO 3 PHONO 4 PHONO 5 PHONO 6 PHONO 7 PHONO 8 PHONO 9 PHONO 0 PHONO	pre code data pre code data pre code data pre code data pre code data pre code data pre code data pre code data pre code data pre code data
DVD	1 OSD 2 TITLE 3 ZOOM 4 MENU 5 10+ 6 SETUP 7 ANGLE 8 SUB-T 9 RESUM 0 AUDIO	activates on-screen display selects title menu zoom mode on/off selects main menu digit entry +10 selects setup menu selects angle selects subtitle resume function selects audio

### For USA setups

Function	Jog Dial command	Note
CDR	1 INPUT 2 INCR 3 SYNC 4 REC 5 PROG 6 TRAY 7 DISP 8 FINAL 9 BLANK 0 REPT	selects input source increments track number activates SYNCRO. recording records pause activates program mode tray open/close display mode finalizes (writes TOC) records blank activates repeat mode

### For REST setups

Function	Jog Dial command	Note
MD	1 REC 2 REPT 3 RANDM 4 DISP 5 EDIT 6 EJCT 7 LP 8 DEL 9 ENTER 0 SYNC	records pause selects repeat mode random play selects display mode selects edit mode eject selects SP/LP mode selects delete selects enter SYNCRO. recording

# TROUBLESHOOTING

**In case of trouble, check the following before calling for service:**

1. Are the connections made properly ?
2. Are you operating the unit properly following user's guide ?
3. Are the power amplifiers and speaker working properly ?

If the unit does not operate properly, check items shown in the following table.

If your trouble cannot be recovered with the remedy actions listed in the following table, malfunction of the internal circuitry is suspected; immediately unplug the power cable and contact your dealer, nearest Marantz distributor or the Marantz Service Center in your country.

SYMPTOM	CAUSE	REMEDY
PS-17 cannot be turned up.	The power plug is not connected.	Connect the power plug to the outlet.
No sound and picture are output even when power is on.	Mute is on. The input cable is not connected correctly. The master volume control is turned all the way down. The function selector position is wrong.	Cancel mute using the remote control unit. See the connection diagram and connect the cables correctly. Adjust the master volume. Select correct position.
Speaker not outputting any sound.	The headphones are connected to the headphone jack. MAIN IN SW=SEPALATE has been selected in SYSTEM mode.	Disconnect the headphones. (Speakers will not output sound when headphones are connected.) Select MAIN IN SW=COUPLED.
Sound and pictures from other than equipment selected with the function selector.	Input cable connected incorrectly.	Connect the cable correctly by referring to the connection diagram.
Sound from the wrong channel is output from the speaker.	Speaker cable connected incorrectly.	Connect the cable correctly by referring to the connection diagram.
No sound is output from the center speaker.	The center speaker cable connection is incomplete. Center = NONE has been selected in SETUP mode. STEREO has been selected for Surround mode. Center components have not been recorded in the input source.	Connect the cable correctly. Make the correct setting. When STEREO is selected for Surround mode, no sound will be output from the center speaker. Set another Surround mode. Check whether "C" on the program channel display in the unit's front panel display area has gone off.
No sound is output from the surround speaker.	The surround speaker cable connection is incomplete. Surround = NONE has been selected in SETUP mode. STEREO has been selected for Surround mode. Surround sound components have not been recorded for the input components.	Connect the cable correctly. Make the correct setting. When STEREO has been selected for Surround mode, no sound will be output from the surround speaker. Set another Surround mode. Check whether "SL" and "SR" on the program channel display in the unit's front panel display area have gone off.
No sound is output from the surround back speaker.	The surround back speaker cable connection is incomplete. Surr. Back=NONE has been selected in SETUP mode. Surround mode is not 6.1 surround. Surround sound components have not been recorded in the input source.	Connect the cable correctly. Make the correct setting. Surround back channel is active in 6.1 surround mode, in other Surround mode, no sound will be output from the surround back speaker.
No output to Sub Woofer Out.	Sub-woofer = NONE has been selected in SETUP mode. Two-channel signals have been played back with SOURCE-DIRECT or PURE-DIRECT selected for the surround mode.	Select Sub-woofer = YES. Select STEREO for the surround mode to play back the 2-channel sound.
DTS sources cannot be played.	Surround mode is set to DOLBY. The DVD or LD player is not DTS digital out capable.	Select other mode. Use a player which responds to DTS-digital out.
96kHz PCM signal cannot be played.	The disc player is not 96kHz PCM digital out capable. Surround mode is set to other than STEREO and AUTO.	Use a player that responds to 96kHz PCM digital out. Set Surround mode to STEREO or AUTO.
A specific channel does not produce output.	Nothing recorded on source.	Check the encoded channel on the source side.
Nothing appears on the FL display, no picture is output from Video MONI.	Surround mode is PURE-DIRECT.	Select other mode.
Nothing appears on the remote commander display.	Batteries are consumed.	Replace all the batteries with new ones.
Control with the remote control unit fails.	Batteries are consumed.. Remote controller's function-key setting is wrong. The distance between this PS-17 and the remote commander is too far. Something is blocking PS-17 and the remote commander.	Replace all the batteries with new ones.. Select different position from which equipment will be controlled. Move closer to this PS-17. Remove offending object.
Sound from the analog turntable is not output or very noisy (hum noise).	Input cable connected incorrectly. Ground cable connected incorrectly. The Cartridge is not attached properly to the tone arm.	Connect the cable cprrectly by referring to the connection diagram. Connect the cable cprrectly by referring to the connection diagram. Check that the cartridge is attached properly to the tone arm. Remove the power plug of the turntable from the power outlet and insert it again by inverting the relationship of the left and right blades with respect to the power outlet slots.

## GENERAL MALFUNCTION

If the equipment malfunctions, this may be because an electrostatic discharge or AC line interference has corrupted the information in the equipment memory circuits. Therefore:

- disconnect the plug from the AC line supply
- after waiting at least three minutes, reconnect the plug to the AC line supply
- re-attempt to operate the equipment

## ERROR MESSAGES

When the display indicates some error messages (e.g. ERROR \*\*), unplug the power cable immediately. Contact your dealer, nearest Marantz distributor or the Marantz service center in your area.

### Last memory

This unit contains a non-volatile memory called as an "EEPROM" to ensure that the following data will be retained in the memory even when the unit's power is turned off.

- inputfunction
- Surroundmode
- OSD SET UP

## HOW TO RESET THE UNIT

Should the operation or display seem to be abnormal, reset the unit with the following procedure.

The PS-17 is turned on, press and hold the **A/D** ③ and **SRS** ⑦ buttons simultaneously for 3 seconds or more.

Remember that the procedure will reset the settings of the function selector, Surround mode, delay time, etc., to their initial settings.

# TECHNICAL SPECIFICATIONS

## POWER AMP SECTION

Rated Power Output (20 Hz to 20 kHz, 2 ch simultaneous drive) .....	60 W · 2 (8 W load)
	80 W · 2 (6 W load)
	100 W · 2 (4 W load)

## AUDIO SECTION

Total harmonic distortion (20 Hz to 20 kHz, 2 ch drive, 8 W load) .....	0.01 %
Cross-modulation distortion (SMPTE) .....	0.01 %
Output bandwidth (8 W load, 0.04 %) .....	10 Hz to 50 kHz
Frequency response .....	5 Hz to 100 kHz (+0 / -1 dB)
Damping factor (8 W load, 20 Hz to 20 kHz) .....	100
Signal to Noise Ratio .....	112 dB

## DECODER SECTION

Decoding .....	PCM Audio (fs=32 kHz, 44.1 kHz)
Frequency response	
Analog input: Source direct .....	5 Hz to 100 kHz (+0 / -1 dB)
Digital input: PCM 96 kHz .....	5 Hz to 45 kHz (+0 / -3 dB)
Signal to Noise Ratio (Source direct mode) .....	104 dB

## VIDEO SECTION

Television Format .....	PAL/NTSC
Input Level/Impedance .....	1 Vp-p/75 W
Output Level/Impedance .....	1 Vp-p/75 W
S/N .....	60 dB
Video Frequency Response	
Video, S-video .....	5 Hz to 10 MHz (+0 / -3 dB)
Component video .....	5 Hz to 45 MHz (+0 / -3 dB)

## GENERAL

Power Requirement .....	AC 230 V 50 Hz
Dimension (MAX)	
Width .....	458 mm
Height .....	166 mm
Depth .....	491 mm
Weight .....	19.0 Kg

## ACCESSORIES

Remote Control Unit RC-17PS .....	1
AA-size batteries .....	2

Specifications subject to change without prior notice.