



marantz®

CD Receiver
M-CR502 DAB

User Guide

ENGLISH

WARRANTY

Your warranty information, contact your local Marantz distributor.

RETAIN YOUR PURCHASE RECEIPT

Your purchase receipt is your permanent record of a valuable purchase. It should be kept in a safe place to be referred to as necessary for insurance purposes or when corresponding with Marantz.

IMPORTANT

When seeking warranty service, it is the responsibility of the consumer to establish proof and date of purchase. Your purchase receipt or invoice is adequate for such proof.

FOR U.K. ONLY

This undertaking is in addition to a consumer's statutory rights and does not affect those rights in any way.

FRANÇAIS

GARANTIE

Pour des informations sur la garantie, contacter le distributeur local Marantz.

CONSERVER L'ATTESTATION D'ACHAT

L'attestation d'achat est la preuve permanente d'un achat de valeur. La conserver en lieu sûr pour s'y reporter aux fins d'obtention d'une couverture d'assurance ou dans le cadre de correspondances avec Marantz.

IMPORTANT

Pour l'obtention d'un service couvert par la garantie, il incombe au client d'établir la preuve de l'achat et d'en corroborer la date. Le reçu ou la facture constituent des preuves suffisantes.

DEUTSCH

GARANTIE

Bei Garantiefragen wenden Sie sich bitte an Ihren Marantz-Händler.

HEBEN SIE IHRE QUITTING GUT AUF

Die Quittung dient Ihnen als bleibende Unterlage für Ihren wertvollen Einkauf. Das Aufbewahren der Quittung ist wichtig, da die darin enthaltenen Angaben für Versicherungszwecke oder bei Korrespondenz mit Marantz angeführt werden müssen.

WICHTIG!

Bei Garantiefragen muß der Kunde eine Kaufunterlage mit Kaufdatum vorlegen. Ihren Quittung oder Rechnung ist als Unterlage ausreichend.

CE MARKING



English

The M-CR502 DAB is in conformity with the EMC directive and low-voltage directive.



Français

Le M-CR502 DAB est conforme à la directive EMC et à la directive sur les basses tensions.



Deutsch

Das Modell M-CR502 DAB entspricht den EMC-Richtlinien und den Richtlinien für Niederspannungsgeräte.

English

WARNINGS

- Do not expose the equipment to rain, moisture, dripping or splashing.
- Do not remove the cover from the equipment.
- Do not insert anything into the equipment through the ventilation holes.
- Do not handle the mains cord with wet hands.
- Do not cover the ventilation with any items such as tablecloths, newspapers, curtains, etc.
- No naked flame sources, such as lighted candles, should be placed on the equipment.
- When disposing of used batteries, please comply with governmental regulations or environmental public instruction's rules that apply in your country or area.
- Make a space of about 0.2 meter around the unit.
- No objects filled with liquids, such as vases, shall be placed on the equipment.
- When the switch is in the OFF position, the equipment is not completely switched off from MAINS.
- The equipment shall be installed near the power supply so that the power supply is easily accessible.
- Do not touch hot spots during and immediately after use.
- During and immediately after use, this product is hot in areas other than the controls and rear panel connection jacks. Do not touch hot spots and especially the top panel. Contact with hot areas can cause burns.
- Do not expose the unit and batteries to excessive heat such as direct sunlight, fire or the like.

Français

AVERTISSEMENTS

- Ne pas exposer l'appareil à la pluie, à l'humidité, à l'égouttement ou aux éclaboussures.
- Ne pas essayer de retirer le boîtier de l'appareil.
- Ne rien insérer dans l'appareil par les orifices de ventilation.
- Ne pas manipuler le cordon d'alimentation avec les mains mouillées.
- Ne pas recouvrir les ouïes de ventilation avec un objet quelconque comme une nappe, un journal, un rideau, etc.
- Ne placer aucune source de flamme nue, comme une bougie allumée, sur l'appareil.
- Pour mettre au rebut les piles usées, respecter les lois gouvernementales ou les règlements officiels concernant l'environnement qui s'appliquent à votre pays ou région.
- Veiller à ce qu'aucun objet ne soit à moins de 0,2 mètre des côtés de l'appareil.
- Aucun objet rempli de liquide, un vase par exemple, ne doit être placé sur l'appareil.
- Lorsque l'interrupteur est sur la position OFF, l'appareil n'est pas complètement déconnecté du SECTEUR (MAINS).
- L'appareil sera installé près de la source d'alimentation, de sorte que cette dernière soit facilement accessible.
- Ne pas toucher aux zones chaudes pendant et immédiatement après l'utilisation.
- Pendant l'utilisation et immédiatement après, cet appareil est chaud en dehors des commandes et des prises de raccordement arrière. Ne pas toucher aux zones chaudes, et particulièrement au panneau supérieur, pour éviter tout risque de brûlure.
- N'exposez pas l'appareil et les piles à une chaleur excessive, comme par exemple aux rayons directs du soleil, au feu, etc.

Deutsch

WARNHINWEISE

- Das Gerät nicht Regen, Feuchtigkeit, Tropf- oder Spritzwasser aussetzen.
- Die Abdeckung nicht vom Gerät abnehmen.
- Keine Gegenstände durch die Belüftungsschlitze stecken.
- Das Netzkabel nicht mit feuchten oder nassen Händen anfassen.
- Decken Sie die Lüftungsöffnungen nicht mit einem Tischtuch, einer Zeitung, einem Vorhang usw. ab.
- Es dürfen keine Gegenstände mit offener Flamme, wie etwa brennende Kerzen, auf dem Gerät aufgestellt werden.
- Beachten Sie bei der Entsorgung der verbrauchten Batterien alle geltenden lokalen und überregionalen Regelungen.
- Auf allen Geräteseiten muß ein Zwischenraum von ungefähr 0,2 meter vorhanden sein.
- Auf das Gerät dürfen keine mit Flüssigkeiten gefüllte Behälter, wie etwa eine Vase, gestellt werden.
- Wenn der Schalter ausgeschaltet ist (OFF-Position), ist das Gerät nicht vollständig vom Stromnetz (MAINS) abgetrennt.
- Das Gerät sollte in der Nähe einer Netzsteckdose aufgestellt werden, damit es leicht an das Stromnetz angeschlossen werden kann.
- Berühren Sie während oder unmittelbar nach dem Gebrauch keine heißen Stellen des Gerätes.
- Während oder unmittelbar nach dem Gebrauch ist dieses Produkt mit Ausnahme der Bedienelemente und der Anschlussbuchsen auf der Rückseite heiß. Berühren Sie die heißen Stellen und insbesondere die Oberseite nicht. Der Kontakt mit heißen Flächen kann zu Verbrennungen führen.
- Setzen Sie das Gerät und die Batterien keiner übermäßigen Wärme aus, z.B. durch Aufstellung in direkter Sonneneinstrahlung, in der Nähe eines offenen Feuers usw.

INTRODUCTION

Thank you for selecting the Marantz M-CR502 DAB CD Receiver for your A/V system. Please read these operating instructions carefully. We recommend that you read the entire user guide before you attempt to connect or operate the player. After you have reviewed the contents of this manual, we suggest that you make all system connections before you attempt to operate the unit.

CHECKING THE ACCESSORIES

After opening the cover of the packing box, check that the following accessories are included.

- Remote controller



- Size "AAA" batteries x 2

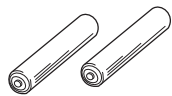

- FM antenna
- AM loop antenna
- DAB antenna
- AC Power cord
- User Guide

A NOTE ABOUT RECYCLING



This product's packaging materials are recyclable and can be reused. This product and the accessories packed together are the applicable product to the WEEE directive except batteries. Please dispose of any materials in accordance with your local recycling regulations. When discarding the unit, comply with your local rules or regulations. Batteries should never be thrown away or incinerated but disposed of in accordance with your local regulations concerning chemical wastes.

CONTENTS

FEATURES	2	ADVANCED OPERATIONS	18
BEFORE USING	2	USING CD AND USB DEVICES EASILY	18
USAGE OF REMOTE CONTROLLER	3	CONVENIENT FUNCTIONS FOR LISTENING TO RADIO BROADCASTS	21
NAMES AND FUNCTIONS.....	4	SETTING AMP CHARACTERISTICS (SPEAKER A, B)...	28
FRONT PANEL.....	4	LISTENING TO MUSIC USING BI-WIRING.....	29
DISPLAY PANEL	4	LISTENING TO MUSIC IN TWO LOCATIONS USING A MULTI-DRIVE CONNECTION	30
REMOTE CONTROLLER.....	5	PERFORMING RESET	31
REAR PANEL	6	IF YOU EXPERIENCE PROBLEMS.....	32
BASIC CONNECTIONS	7	GENERAL	32
CONNECTING SPEAKERS.....	7	REMOTE CONTROL OPERATIONS.....	32
CONNECTING THE AM/FM ANTENNAS.....	8	CD AND USB OPERATIONS.....	32
CONNECTING USB DEVICES.....	9	RADIO OPERATIONS.....	33
CONNECTING AN EXTERNAL DEVICE	9	OPERATING EXTERNAL EQUIPMENT	33
CONNECTING HEADPHONES	10	MISCELLANEOUS.....	34
CONNECTING THE POWER CABLE.....	10	SPECIFICATIONS AND EXTERNAL DIMENSIONS ..	34
BASIC OPERATIONS.....	11	NOTES ABOUT THE DISCS	35
SETTING POWER TO ON/STANDBY	11	DISCS THAT CAN BE PLAYED BACK	35
LISTENING TO A CD	11	ABOUT PLAYING COPY-CONTROLLED CDS.....	35
LISTENING TO AM/FM BROADCAST	12		
LISTENING TO MUSIC STORED ON A USB DEVICE ...	13		
LISTENING TO AN EXTERNAL DEVICE	14		
BASIC SETTINGS.....	15		
SETTING THE TIME	15		
USING THE TIMER.....	15		
ADJUSTING THE TONE	16		
CHANGING THE BRIGHTNESS OF THE DISPLAY PANEL.....	16		
SETTING ECO MODE.....	16		
PRACTICAL CONNECTIONS.....	17		
REMOTE CONTROL CONNECTION.....	17		

NAMES AND FUNCTIONS
 BASIC CONNECTIONS
 BASIC OPERATIONS
 BASIC SETTINGS
 PRACTICAL CONNECTIONS
 ADVANCED OPERATIONS
 IF YOU EXPERIENCE PROBLEMS
 MISCELLANEOUS

FEATURES

- **INCORPORATES 4 HIGH-QUALITY DIGITAL AUDIO AMPLIFIERS.**
- **INCORPORATES A BI-AMP SYSTEM TO REALIZE FULL PERFORMANCE OF THE BI-WIRING SPEAKER SYSTEM.**
- **ALLOWS SWITCHING BETWEEN SPEAKERS A AND B AND SIMULTANEOUS PLAYBACK ON SPEAKERS A AND B.**
- **ALLOWS PLAYBACK OF MP3/WMA AUDIO SOURCES THROUGH USE OF THE USB CONNECTOR ON THE FRONT PANEL.**
- **EQUIPPED WITH SCREW-IN SPEAKER TERMINALS FOR SECURE CONNECTIONS.**
- **STYLISH DESIGN THAT HIDES REAR PANEL CONNECTION TERMINALS FROM VIEW FROM ABOVE.**
- **PROVIDES 3.5-MM DIAMETER EXTERNAL INPUT JACKS ON THE FRONT PANEL FOR EASY CONNECTION TO A DIGITAL AUDIO PLAYER.**
- **SUPPORTS DAB BAND III**

BEFORE USING

This section must be read before any connection is made to the mains supply.

EQUIPMENT MAINS WORKING SETTING

Your Marantz product complies with the household power and safety requirements in your area. This product can be powered by 230 V AC only.

COPYRIGHT

Recording and playback of any material may require consent. For further information refer to the following:

- Copyright Act 1956
- Dramatic and Musical Performers Act 1958
- Performers Protection Acts 1963 and 1972
- any subsequent statutory enactments and orders

INAPPROPRIATE PLACES FOR INSTALLATION

To keep your player in perfect working order for the longest possible time, avoid installing the player in the following locations.

- Wherever it will be exposed to direct sunlight
- Wherever it will be close to a heater or other heat-radiating appliance
- Wherever the humidity is high or ventilation is poor
- Wherever it is very dusty
- Wherever it will be subject to vibration
- On top of a rickety stand or in an unstable location which is tilted at an angle
- On top of an amplifier or other component which dissipates a great deal of heat
- In an audio rack with little space at the top and bottom or other location where the heat dissipation will be obstructed

To ensure proper heat dissipation, install the player while leaving clearances between the player and wall or other components, as shown in the figure below.

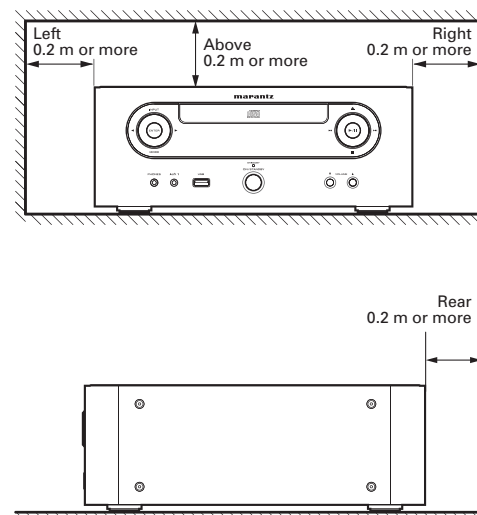

DO NOT PLACE OBJECTS ON TOP

Refrain from placing any objects on top of the player.

CAUTIONS ON HANDLING MAINS CORD

- Do not touch the mains cord with wet hands.
- When disconnecting the mains cord, always make sure that you take hold of the plug. Yanking out or bending the cord can damage it and/or cause electric shocks or a fire.
- Get into the habit of disconnecting the power plug before leaving home.

DO NOT ATTEMPT REPAIRS YOURSELF

- Refrain from lubricating the player: doing so can cause malfunctioning.
- Only qualified engineers with specialized expertise are authorized to repair the pick-up and parts inside the player.

PRECAUTIONS

- In winter, droplets of water form on the insides of the windows of a heated room: this is called condensation. This CD player uses an optical lens, so the condensation may form in the following cases.
 - In a room immediately after the heating has been turned on
 - In a room where the humidity level is high
 - When the player has been suddenly brought from a cold location into a warm room

Since, in cases like this, the track numbers may not be read and the player is prevented from operating properly, wait about 30 minutes, and then operate the player.

- This player may cause interference on a tuner or TV set. If this is the case, place it further away from the tuner or TV set.
- Compact discs have much less noise than analog records and hardly any noise is heard before play starts. Bear in mind, therefore, that if the volume control on the amplifier is set too high, you will risk damaging other audio components.
- This audio player is for the exclusive playing of Audio CDs (Compact Discs) and MP3/WMA compressed data files. It cannot play CD-ROMs used with personal computers, game CDs, video CDs, DVDs (video/audio) or DTS-CDs.
- We do not recommend the use of lens cleaners.

USAGE OF REMOTE CONTROLLER

LOADING BATTERIES

Before using the remote controller for the first time, load the batteries in the remote controller. The batteries provided are used to verify the operations of the remote controller only.

1. Remove the battery cover.

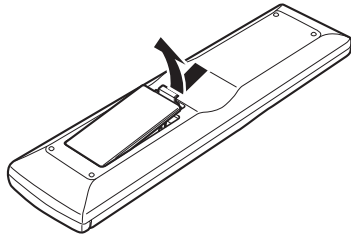

2. Insert the batteries with correct +/- orientation.

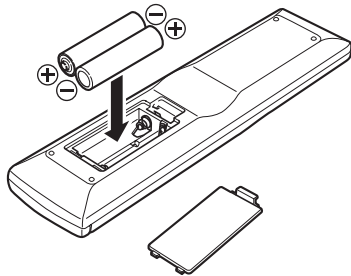

3. Close the battery cover until it clicks shut.

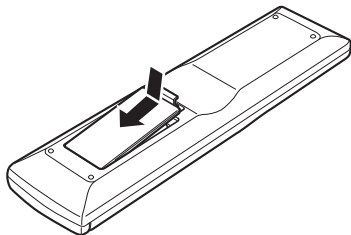

CAUTIONS ON HANDLING BATTERIES

Misuse of the batteries can result in electrolyte leakage, rupturing, corrosion, etc.

Bear in mind the following points when using batteries.

- Remove the batteries from the remote control unit if the unit is not going to be used for a prolonged period (a month or more).
- Do not use an old battery together with a new one.
- Insert the batteries while ensuring that their \oplus and \ominus poles are properly aligned with the corresponding markings on the remote control unit.
- Batteries with the same shape may have different voltages. Do not use different types of batteries together.
- If electrolyte has leaked, thoroughly wipe the inside of the battery compartment, and then insert new batteries.
- When batteries which are no longer required are to be discarded, follow the directions (regulations) laid down by the local authorities in the area concerned for their disposal.

OPERATIONAL RANGE

Operate the unit with the remote controller within the range of the illustration below.

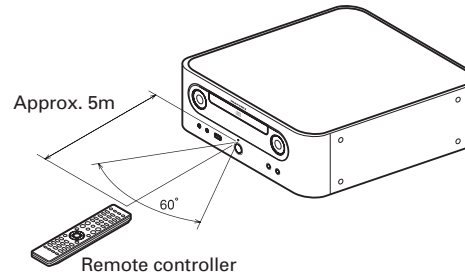

Precautions:

- Do not allow direct sunlight, an inverter fluorescent light or other strong source of light to shine onto the player's infrared signal reception window (remote sensor). Otherwise, the operation of the remote control unit may be disabled.
- Bear in mind that operating the remote control unit may cause other devices operated by infrared rays to be operated by mistake.
- The remote control unit cannot be operated if the space between the controller and the player's remote sensor is obstructed.
- Do not place any objects on top of the remote control unit. Doing so may cause one or more buttons to be held down which will cause the batteries to run down.

NAMES AND FUNCTIONS

FRONT PANEL

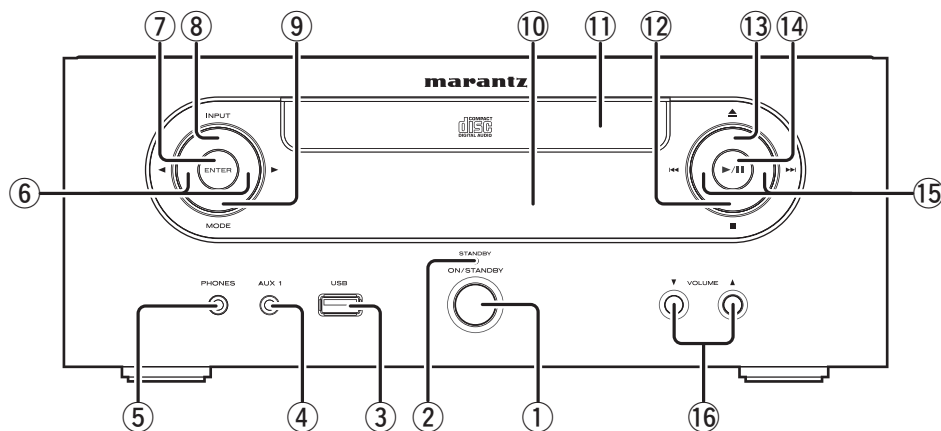

① POWER ON/STANDBY switch

See page 11.

② STANDBY indicator

Lights when the unit is in standby mode.

③ USB input port

Used to connect USB devices.

④ AUX1 input jack

Used to connect portable audio devices.

⑤ PHONES jack

Used to connect headphones.

⑥ ◀▶ buttons

• SET UP mode

Used to select the item to be set. (See page 22, 23, 27, 31)

• TUNER mode

Used when switching frequencies or setting preset numbers. (See page 12, 21)

⑦ ENTER button

Used to confirm an item. (See page 16, 22, 23, 27, 31)

• TUNER mode

Used to register a broadcast station. (See page 21)

⑧ INPUT button

Selects the input source.

⑨ MODE button

• SET UP mode

Calls up the SETUP menu when pressed continuously. (See page 22, 23, 27, 31)

• TUNER mode

Used to name registered broadcast stations. (See page 22)

⑩ Display

Displays play status, settings, etc.

⑪ Disc tray

Tray used to insert a compact disc.

⑫ ■ (STOP) button

See page 11.

⑬ ▲ (OPEN/CLOSE) button

Used to open/close the disc tray.

⑭ ▶/|| (PLAY/PAUSE) button

See page 11.

⑮ ◀▶ buttons

• TUNER mode

Selects the previous/next preset channel. (See page 22)

• CD/USB mode

Selects the previous/next track. (See page 13)
Fast forwards and rapid rewinds when pressed continuously.

⑯ VOLUME ▲ up button

VOLUME ▼ down button

Adjusts the audio volume.

DISPLAY PANEL

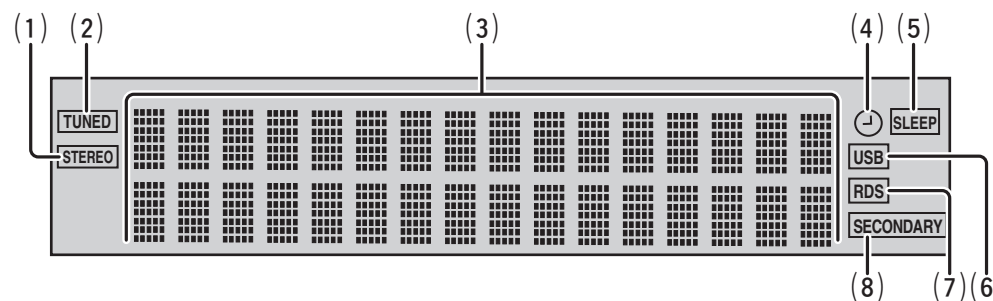

(1) STEREO indicator

Lights when receiving an FM stereo broadcast.

(2) TUNED indicator

Lights when receiving a broadcast station.

(3) Main display

Displays the track and track information when playing a CD or USB device. Displays the frequency of the broadcast station being received when using the tuner.

(4) Timer indicator

Lights when the wake-up timer function has been enabled.

(5) SLEEP indicator

Lights when the sleep timer function has been enabled.

(6) USB indicator

Lights when a USB device has been detected.

(7) RDS indicator

Lights when RDS is being received.

(8) SECONDARY indicator

Lights when the selected DAB service is Secondary DAB service.

REMOTE CONTROLLER

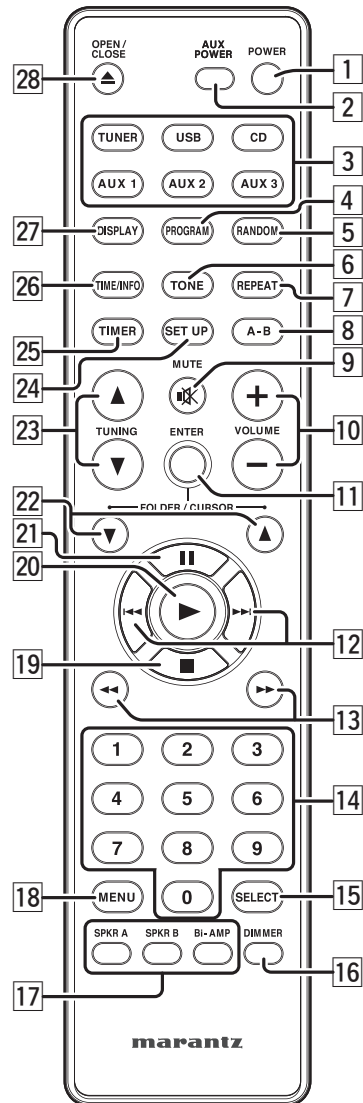

COMMON OPERATIONS

1 POWER button

Used to turn on the unit's power or put the unit in standby mode.

2 AUX POWER button

Used to turn on the power of an iPod connected to IS201 or put it in standby mode.

3 Input source select button

Selects the input source.

Note:

The TUNER button is also used to switch between AM, FM and DAB.

6 TONE button

Adjusts the audio tone. (See page 16)

9 MUTE button

Mutes audio output. If pressed again, muting is canceled and the original volume level is restored.

10 VOLUME + button, VOLUME - button

Adjust the audio volume.

11 ENTER button**15 SELECT button**

Performs the same operations as the click wheel select button on an iPod.

16 DIMMER button

Adjusts the brightness of the display panel. (See page 16)

17 Speaker mode select button

Selects the speaker mode by pressing the button matching the connected speaker terminals.

18 MENU button

Performs the same operations as the click wheel MENU button on an iPod.

24 SET UP button

Calls up the SETUP menu. (See page 22, 23, 27, 31)

25 TIMER button

Used to adjust the clock, turn the timer ON/OFF, and set SLEEP mode. (See page 15)

27 DISPLAY button

Displays the time and timer setting. (See page 15)

CD/USB OPERATIONS (CD/USB MODE)

4 PROGRAM button

Initiates program play. (See page 19)

5 RANDOM button

Plays tracks in random order. (See page 18)

7 REPEAT button

Repeatedly plays a given track or all tracks on a given disc. (See pages 18)

8 A-B (A-B repeat) button

Sets the start point, A, and end point, B, to use when repeatedly playing a specified part of a disc. (See pages 18)

12 ►► (next track) button**◄◄ (previous track) button**

Advances to the start of the next track. Returns to the start of the current track or start of the previous track.

13 ►► (fast forward) button**◄◄ (rapid rewind) button**

Fast forwards when held down during playback. Rapid rewinds when held down during playback.

14 Numeric button group

Used to specify the track number to be played.

19 ■ (stop) button

Stops playback.

20 ► (play) button

Starts playback.

21 || (pause) button

Pauses playback.

NAMES AND FUNCTIONS

22 FOLDER/CURSOR ▼ button FOLDER/CURSOR ▲ button

Selects the folder for MP3/WMA playback. (See page 13)

26 TIME/INFO button

Switches the time/text display during playback. (See page 20)

28 OPEN/CLOSE ▲ button

Opens/closes the disc tray.

TUNER OPERATIONS (TUNER MODE)

11 ENTER button

Used to register (preset) a broadcast station. (See page 21)

12 ►► (next preset) button

◄◄ (previous preset) button

Selects the next preset channel. (See page 22)

Selects the previous preset channel. (See page 22)

14 Numeric button group

Used to set preset numbers and select preset channels. (See page 22)

23 TUNING ▼ button

TUNING ▲ button

Used to increase/decrease the frequency being received. (See page 12)

REAR PANEL

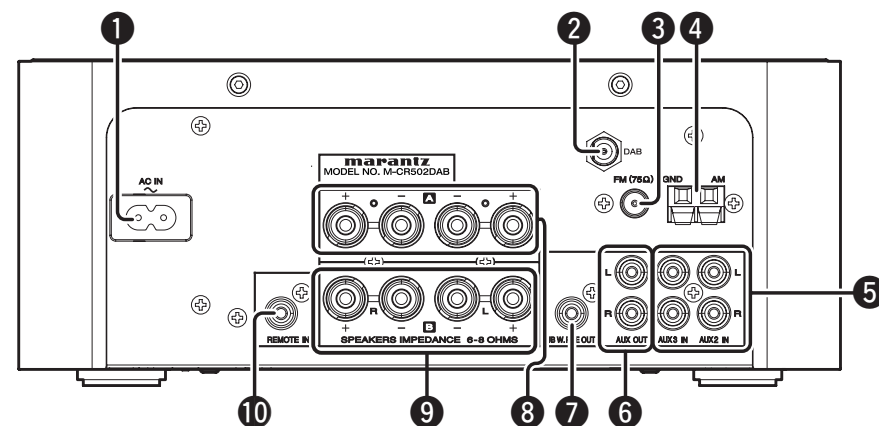

1 AC Power cord connector socket

Connect to the supplied AC power cord.

2 DAB antenna terminal

Connect to the supplied DAB antenna.

3 FM antenna terminal

Connect to the supplied FM antenna. Connect to an external antenna if reception is poor.

4 AM antenna terminal

Connect to the supplied AM antenna.

5 AUX IN terminal

Connect to an IS201 Music Junction for the iPod from Marantz or CD player.

6 AUX OUT terminal

Connect to an external pre-main amplifier.

7 SUB W. PRE OUT terminal

Connect to the input terminal of a powered subwoofer.

8 Speaker A output terminals

Connect to the speakers.

9 Speaker B output terminals

Connect to the speakers.

10 REMOTE IN terminal

Connect to the REMOTE CONTROL output terminal of Marantz products.

BASIC CONNECTIONS

CONNECTING SPEAKERS

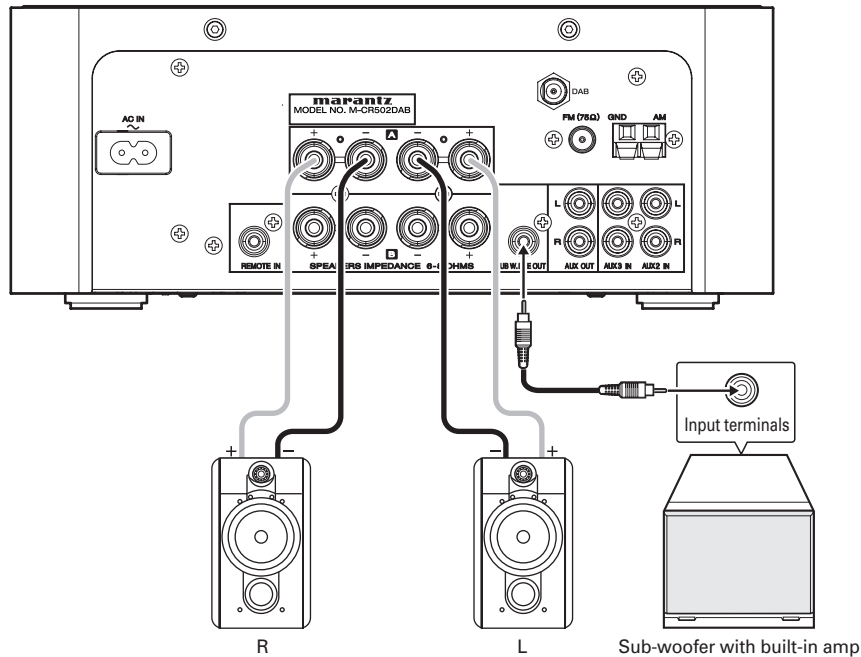

Notes:

- Always be sure to use speakers having the impedance specifications listed on the unit's rear panel.
- To prevent damage to the circuit, do not allow speaker wires to come in contact with each other or with metallic parts of the unit.

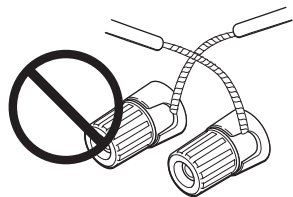

- Do not touch speaker terminals when the power is ON as there is a risk of electric shock.
- Do not connect more than one speaker cable to one speaker terminal as there is risk of damage to the unit.
- Make certain that the polarity is correct when connecting to the speaker terminals. If the polarity is incorrect, the signal phase will become inverted and the music being played will sound unnatural.

CONNECTING SPEAKER CABLES

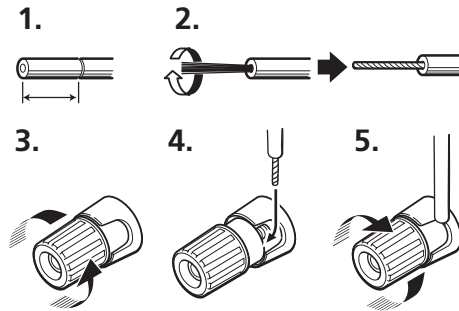

1. Strip approximately 10 mm of insulation from the ends of the speaker cables.
2. Tightly twist the exposed strands of speaker wire in order to prevent shorting.
3. Turn the speaker terminal counterclockwise to loosen the terminal.
4. Insert the exposed part of the speaker cable into the hole on the side of the speaker terminal.
5. Turn the speaker terminal clockwise to tighten the terminal.

CONNECTING A SUBWOOFER

Be sure to use the audio output terminal for a sub-woofer on the unit when connecting to a powered sub-woofer (a sub-woofer with built-in powered amp). For details on making connections, see the instruction manual for your sub-woofer.

SETTING SPEAKER OUTPUTS

After turning on the unit's power (See page 11), set the speaker output for the unit to match the speaker connections made to terminals A and B. The default setting is SPKR A.

Note:

Be sure to lower the audio volume before making speaker settings.

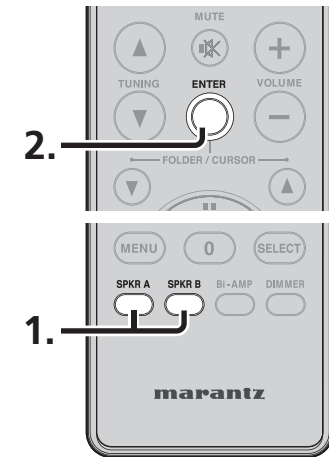

1. Press the SPKR A or SPKR B button to match speaker connections made to A and B terminals.

Note:

Once the SPKR A or B button on the remote controller is pressed, the display returns to normal after 3 seconds elapse.

2. Press the ENTER button. The display changes from flashing to lit.

BASIC CONNECTIONS

CONNECTING THE AM/FM ANTENNAS

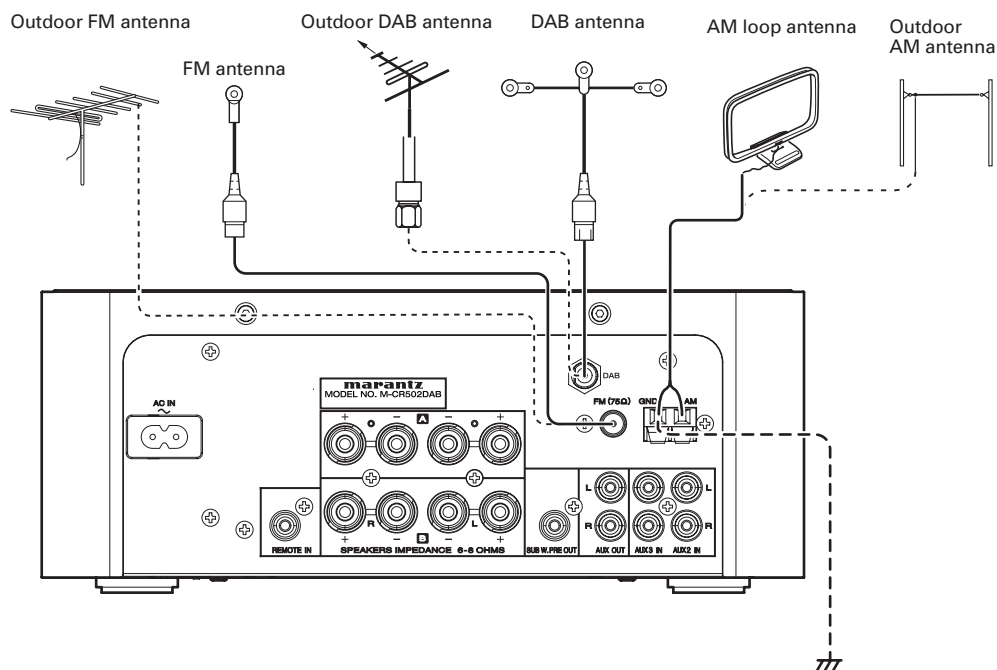

CONNECTING THE SUPPLIED ANTENNAS

CONNECTING THE SUPPLIED FM ANTENNA

Be sure to use the supplied FM antenna indoors. To use, extend and adjust the antenna's positioning until clear reception is achieved. Use push pins or other such implement to secure the antenna in the location with the least noise.

CONNECTING THE SUPPLIED DAB ANTENNA

Be sure to use the supplied DAB antenna indoors. Adjust the antenna up and down to optimize reception (see TUNING AID on page 27). Fix to a location such as a window frame or wall with tape or push pins.

CONNECTING THE SUPPLIED AM ANTENNA

Be sure to use the supplied AM loop antenna indoors. Orient the antenna in a position that allows clear reception. Place the antenna as far as possible from the unit, TV, speakers, and electric cords.

1. Push down the levers on the AM antenna terminals.
2. Insert the stripped leads of the antenna wire into the antenna terminal.
3. Release the levers.

Note:

Connect the GND wire (black) of the shielded cable to the GND terminal of the AM antenna.

ASSEMBLING THE AM LOOP ANTENNA

1. Unwind the antenna wire.

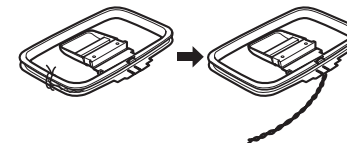

2. Bend the stand in the opposite direction.



3. Insert the hook at the bottom of the loop into the groove in the stand.



4. Place the antenna on a stable surface.

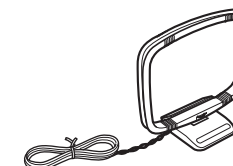

CONNECTING THE OUTDOOR ANTENNAS

Poor reception may sometimes be improved by installing an outdoor antenna.

CONNECTING THE OUTDOOR FM ANTENNA

Notes:

- Install the antenna away from noise sources (such as neon signs, roads with heavy traffic, etc.)
- Install the antenna away from power lines, transformers, and other electric power equipment.
- Always ground the antenna to prevent damage from lightning and electric shock.

CONNECTING THE OUTDOOR AM ANTENNA

Notes:

- Do not disconnect the AM loop antenna.
- Always ground the antenna to prevent damage from lightning and electric shock.

CONNECTING USB DEVICES

A USB device storing compressed MP3 or WMA music data files may be connected.

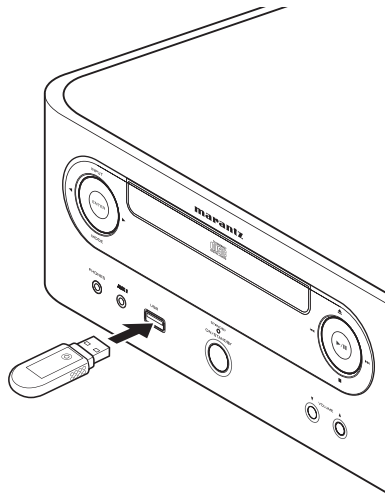

Note:

Connect the USB device while the unit is in standby mode or when the input source is set to other than USB. Data stored on the USB device may be destroyed if the USB device is connected or disconnected while power is on and the input source is set to USB.

CONNECTING AN EXTERNAL DEVICE

The audio output jack of a portable music player may be connected to the AUX IN (external input) terminal of the unit using a commercially available audio cable with 3.5-mm diameter stereo mini-plugs.

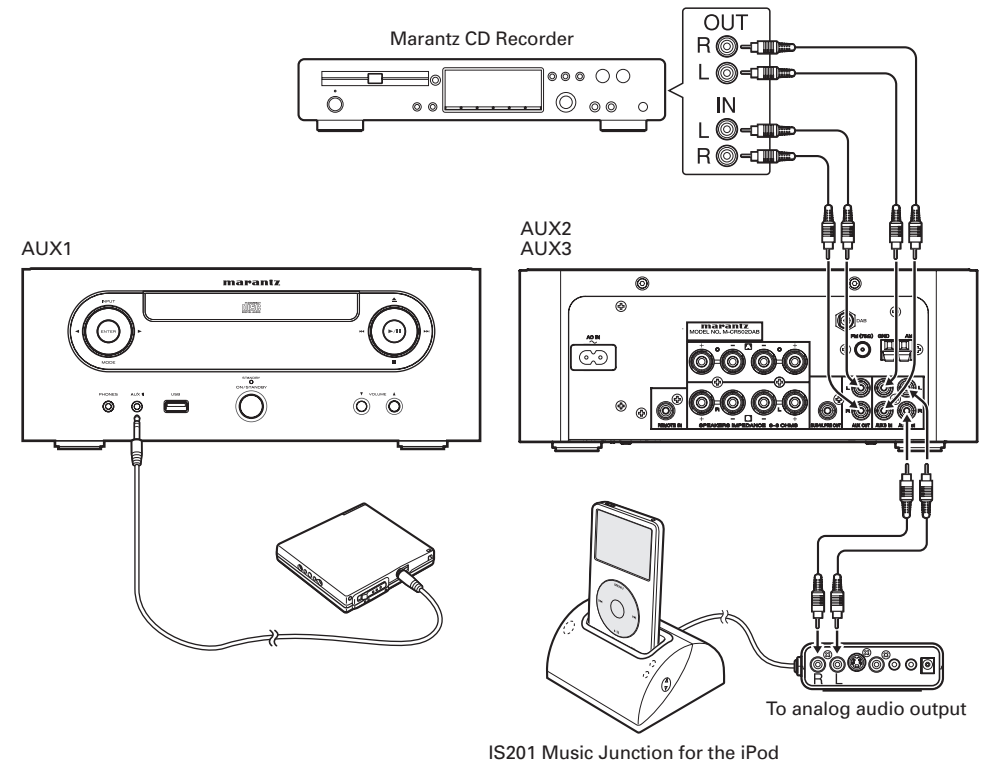

Notes:

- Turn off the power of all devices before making connections.
- Insert the plug securely. An unsecured connection may result in noise.
- Hum or noise may result when using a USB device with USB connector if connection is made to both the connection cord and USB connector, or when the connection cord becomes wrapped around the power cable.
- When making connections, take care that the audio volume level of the receiver unit and any other external connected units are not set too high.

BASIC CONNECTIONS

CONNECTING HEADPHONES

Connect the 3.5-mm diameter headphone plug into the PHONES jack on the unit.

- When headphones are connected, audio ceases to be output from the speakers of this unit.

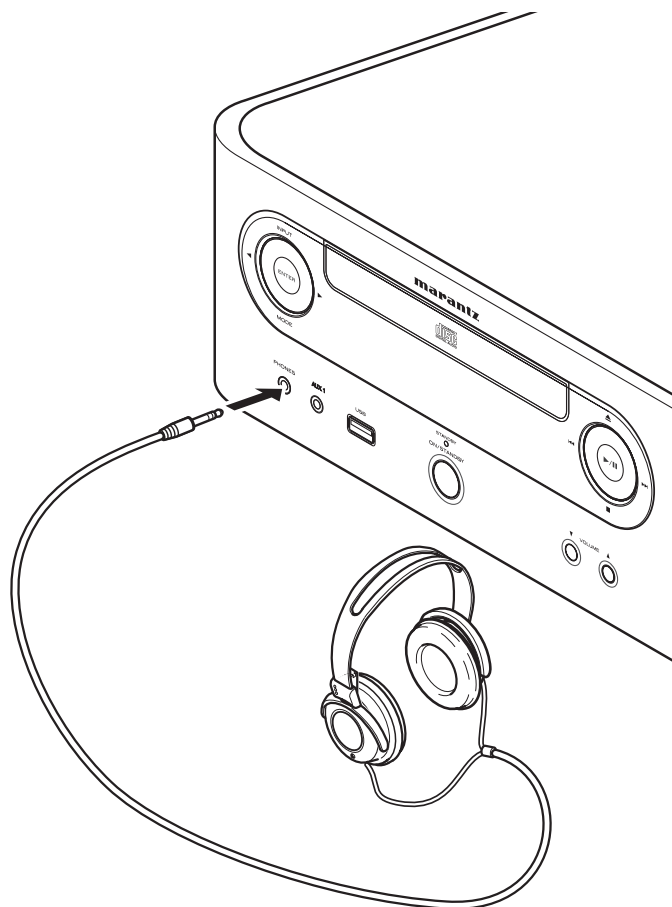

CONNECTING THE POWER CABLE

- Plug the supplied power cable into AC power cord connector socket on the unit.
- Plug the power cable into a power outlet.

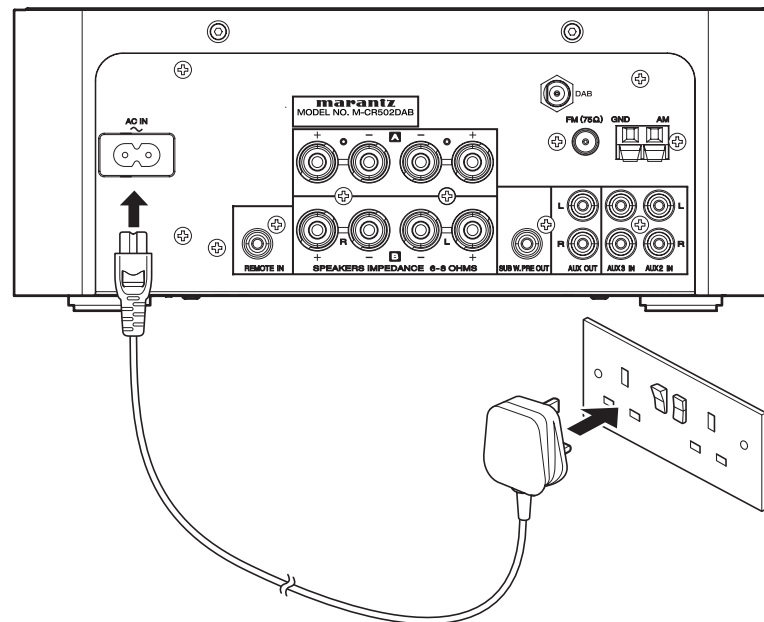

Note:

When making connections, take care that the audio volume level of the unit is not set too high.

Note:

The unit is in constant power on mode (standby mode) while the power cable is connected. Be sure to unplug the power cable to completely turn off power to the unit. Note, however, that the time and timer settings must be made again when the power cable is re-connected.

BASIC OPERATIONS

SETTING POWER TO ON/STANDBY

Before turning on the power, check again that all speaker and antenna connections have been made correctly.

Turn the power on by pressing the ON/STANDBY button on the unit.

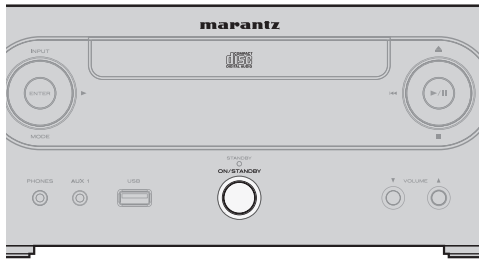

Turn the power on by pressing the POWER button on the remote controller.



When the power is turned on, the input source last used is displayed on the display panel. If the power is set to standby mode, the display panel displays the time.

- The display flashes "00:00" at time of purchase. Be sure to set the time. (See page 15)

LISTENING TO A CD

The unit can also play MP3 and WMA music data files written on a CD-R or CD-RW disc in ISO9660 Mode 1 or Mode 2 CD-ROM format.

Be sure to adjust the audio volume level of the unit before listening to a CD.

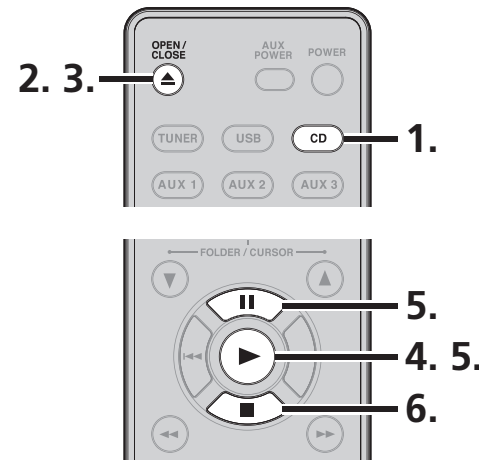
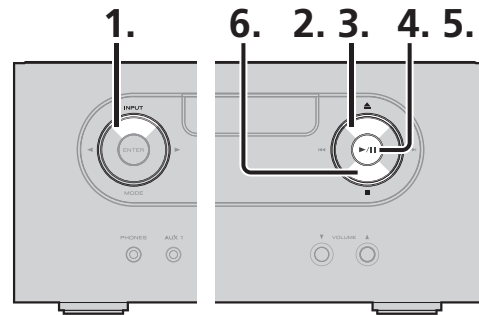

- Select CD as the input source by pressing the INPUT button on the unit or the CD button on the remote controller.

Note:

When changing the input source to CD using the INPUT button on the unit, be sure to put the remote controller into CD/USB mode by pressing its CD button.

- Open the disc tray by pressing the ▲ button and then place the CD on the disc tray. Make sure that the printed label is facing up when placing the CD on the tray.

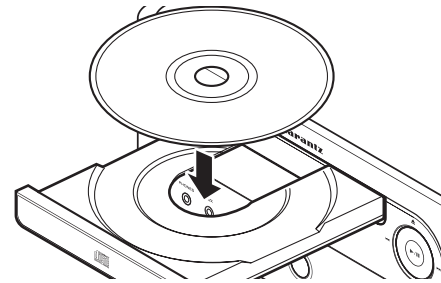

- Close the disc tray by pressing the ▲ button again.
 - A display like that given below appears on the display panel after disc information has been read.



PLAYING A CD

- Start playing the CD by pressing the ►/|| button on the unit or the ► button on the remote controller.
 - Adjust the volume to your taste when playback starts using the volume buttons on the unit or remote controller.



- Play the CD by pressing the ►/|| button on the unit; or the ► button, RANDOM button, or any of the numeric buttons on the remote controller while the disc tray is closed.

PAUSING PLAYBACK

- Pause playback by pressing the ►/|| button on the unit or the || button on the remote controller during playback.



- Resume playback by again repressing the ►/|| button on the unit or the ► button or the || button on the remote controller.

STOPPING PLAYBACK

- Stop playback by pressing the ■ button on the unit or remote controller.



BASIC OPERATIONS

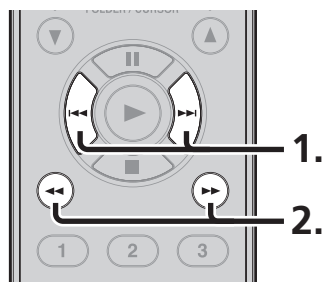
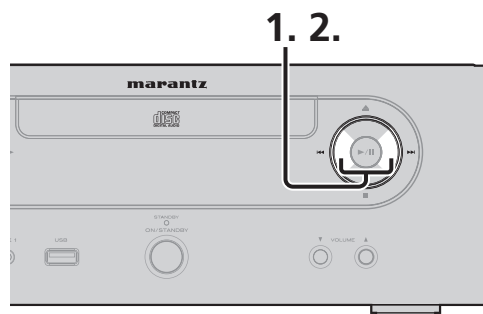

PLAYING THE NEXT TRACK

1. Play the next track by pressing the ►► button during playback.
2. If you want to play tracks even further ahead of the current track, the track number changes equal to the number of times the ►► button is pressed.
 - Selecting a track number using the numeric keys on the remote controller will automatically play that track.
 - Press the numeric keys on the remote controller in succession to select a track number equal to or greater than 10.

For example, press 1 followed by 8 on the remote controller if you want to listen to track 18. Note that playback starts from track 1 if 8 is not entered within 3 seconds after having entered 1.

FAST FORWARD AND RAPID REWIND

- It is possible to quickly find the part of a track you want to listen to.
- The audio volume output by the speakers is reduced during fast forward/rapid rewind.

RAPID REWIND

Hold down the ◀◀ button on the unit or the ◀◀ button on the remote controller during playback until you find the track section you want to listen to. Start playback by releasing the button when you find the section you want to listen to.

FAST FORWARD

Hold down the ►► button on the unit or the ►► button on the remote controller during playback until you find the track section you want to listen to. Start playback by releasing the button when you find the section you want to listen to.

PLAYING THE PREVIOUS TRACK

1. Start playback from the beginning of the track currently being played by pressing the ◀◀ button during playback.
2. If you want to play to the track before the current track, move to the previous track by pressing the ◀◀ button two times in succession.

LISTENING TO AM/FM BROADCAST

Before listening to a radio broadcast, be sure to check that the AM and FM antennas are properly connected to the unit.

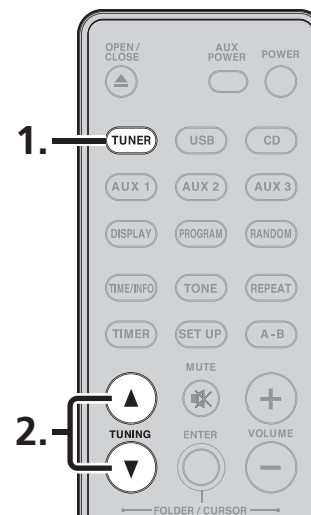
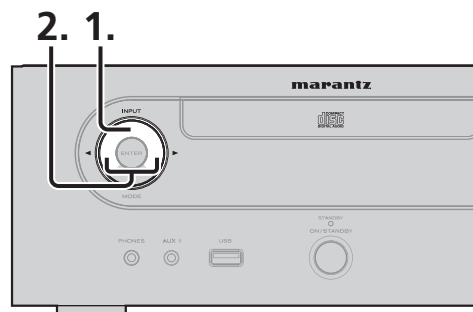

1. Select FM or AM as the input source using the INPUT button on the unit or the TUNER button on the remote controller.

Note:

When changing the input source to FM or AM using the INPUT button on the unit, be sure to put the remote controller into TUNER mode by pressing its TUNER button.

AUTOMATICALLY SELECTING A STATION

2. Holding down either of the ◀► buttons on the unit or either of the TUNNING ▲▼ buttons on the remote controller for more than 1 second automatically selects the frequency of the next receivable station in the direction indicated.
3. "TUNED" lights on the display panel while receiving a broadcast station.
 - "STEREO" lights on the display panel while receiving a stereo broadcast on an FM channel.

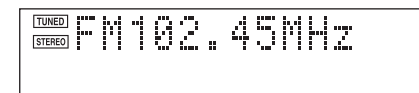

MANUALLY TUNING A BROADCAST STATION

2. Adjust to the frequency of the broadcast station you want to listen to by pressing either of the ◀► buttons on the unit or either of the TUNING ▲▼ buttons on the remote controller.
3. "TUNED" lights on the display panel while receiving a broadcast station.

Notes:

- Be sure to select "FM MONO" on the SETUP menu if there is a lot of noise on the FM broadcast station. (See page 22)
- Be sure to use an external antenna to receive FM broadcast stations with a weak signal.

LISTENING TO MUSIC STORED ON A USB DEVICE

- The unit can play data files stored on a USB device in MP3 (MPEG Audio Layer 3) or WMA (Windows Media Audio) file format.
- The unit can display ID3 tag information in the case of files that support MP3 ID3 Tag Version 1 if ID3 tag information has been recorded. (See page 21)



- Windows Media and the Windows logo are trademarks or registered trademarks of Microsoft Corporation in the United States and other countries.
- Due to copyright laws, music recorded by the customer cannot be used for any purpose other than personal use without authorization from the copyright holder.

Notes:

- Marantz does not guarantee the operation of, or supply of power to, any USB devices.
- Marantz bears no responsibility if for some reason data stored on a USB device is damaged or lost when the USB device is connected to the unit.
- The unit can play files up to 4GB in size.

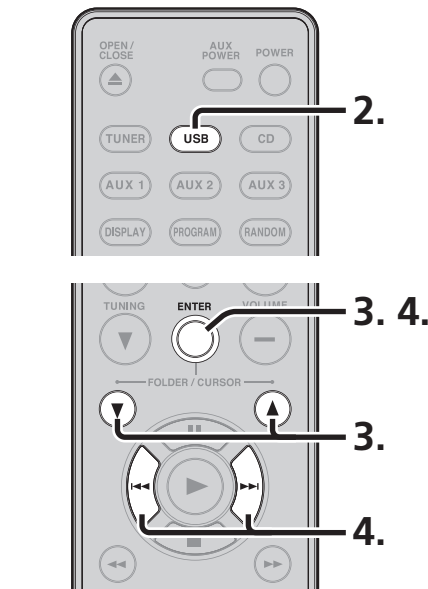
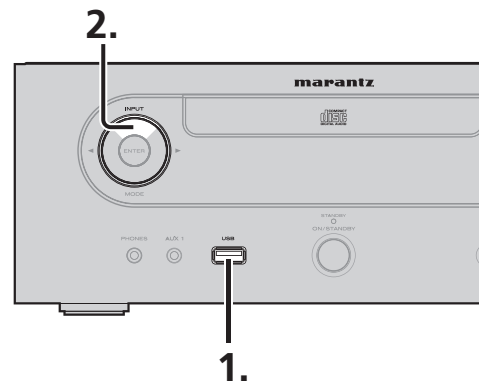

1. Connect the USB device to the unit.

Note:

Connect the USB device while the unit is in standby mode or when the input source is set to other than USB. Data stored on the USB device may be destroyed if the USB device is connected or disconnected while power is on and the input source is set to USB.

2. Select USB as the input source using the INPUT button on the unit or USB button on the remote controller
“No file” is displayed on the display panel if there are no music files (MP3/WMA) on the USB device.
 - Play automatically starts if there are music files on the USB device.



- A scrolling display of “Track Name,” “Artist Name,” and “Album Name” appears when playing an MP3/WMA disc or USB device.

Note:

When changing the input source to USB using the INPUT button on the unit, be sure to put the remote controller into CD/USB mode by pressing its USB button.

3. Select a folder by pressing either of the FOLDER/CURSOR ▲/▼ buttons and then the ENTER button.

Note:

“ROOT” is displayed on the display panel if you press the FOLDER button and no folder is found.

4. Select a file in the folder by pressing the ◀◀ or ▶▶ button and then the ENTER button on the remote controller to start playing the selected file.
 - Files can be selected quickly by holding down the ◀◀ or ▶▶ button for 1 or more seconds.

Note:

File names cannot be displayed on the display panel when searching for a file on a USB device. Only file numbers will be displayed.

BASIC OPERATIONS

LISTENING TO AN EXTERNAL DEVICE

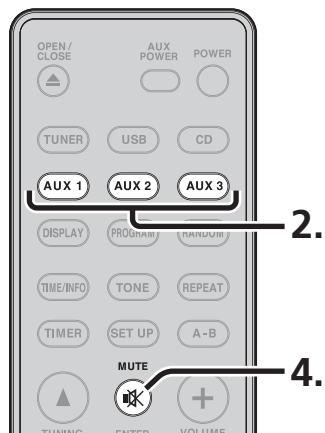
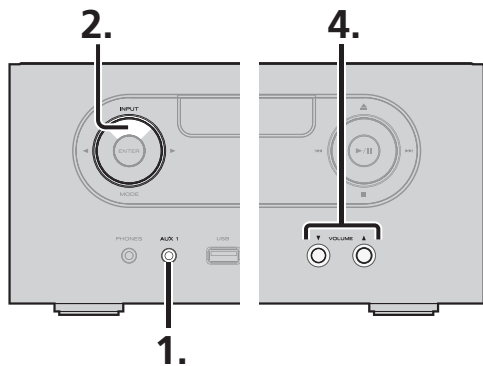
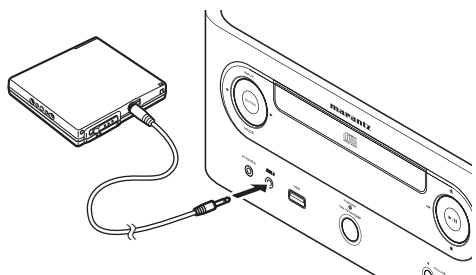

1. Connect external devices (mobile audio devices) to AUX1 located on the front panel of the unit. Connect the IS201 Music Junction for the iPod from Marantz or other external devices to AUX2 or AUX3.
2. Select the external device you want to listen to using the INPUT button on the unit or the AUX button on the remote controller.
 - Select AUX1 to play the device connected to the AUX1 jack located on the front panel of the unit.
3. Start playing the external device.
4. Adjust the audio volume to your taste on the unit or the remote controller.
 - Mute audio output by pressing the MUTE button on the remote controller. Restore audio output by repressing the MUTE button.

REMOTE CONTROL OPERATION OF THE IS201 MUSIC JUNCTION FOR THE IPOD FROM MARANTZ

Perform the following operations using the supplied remote controller.

Note:

When performing the operations given below, be sure to put the remote controller into common operation mode by pressing the AUX 1 ~ 3 buttons.



AUX POWER button	Switches the power of the iPod connected to the IS201 to on or standby mode.
▲ button	Performs the same operation as turning the iPod click wheel counterclockwise. Note: <i>The audio volume of an iPod cannot be adjusted.</i>
▼ button	Performs the same operation as turning the iPod click wheel clockwise. Note: <i>The audio volume of an iPod cannot be adjusted.</i>
SELECT button	Performs the same operation as the select button on the iPod click wheel.
MENU button	Performs the same operation as the MENU button on the iPod click wheel.
REPEAT button	Switches the repeat mode of the iPod (1 track → All tracks → Off).
RANDOM button	Switches the shuffle mode of the iPod (Track → Album → Off).
■ button	Stops playback of the iPod.
⏸ button	Pauses playback of the iPod.
▶ button	Starts playback of the iPod.
◀◀ button	Returns to the start of the track currently being played when pressed once. Returns to the start of the immediately previous track when pressed twice.
◀◀◀ button	Rapid rewinds beginning from the location currently being played.
▶▶ button	Fast forwards beginning from the location currently being played.
▶▶▶ button	Skips to the start of the next track when pressed once.

BASIC SETTINGS

SETTING THE TIME

Operations are performed using the remote controller.

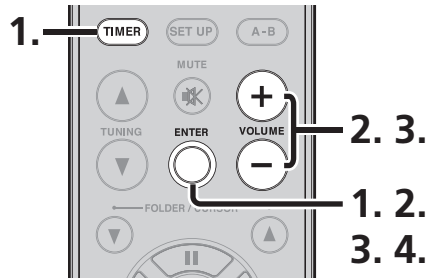

1. Select "TIME" by pressing the TIMER button and then press the ENTER button.



2. Adjust the hour setting using the VOLUME +/- buttons while the hour indicator is flashing on the display panel and then press the ENTER button.



3. Adjust the minute setting using the VOLUME +/- buttons while the minute indicator is flashing and then press the ENTER button.



4. Confirm the time setting and exit time setup by pressing the ENTER button while the hour and minute indicators are flashing. The hour and minute indicators will switch from flashing to constantly lit at this time.



Note:
The time setting is invalid if the time is not entered or the ENTER button is not pressed within 10 seconds while the hour and minute indicators are flashing.

USING THE TIMER

SETTING THE WAKE-UP TIMER

This function turns on the power of this unit and plays the selected input source when the specified time arrives.

- Notes:**
- Be sure that the unit has been set to the correct time before setting the timer.
 - Be sure that a CD has already been loaded beforehand if the input source for the timer is set to CD.
 - Be sure that a USB device that contains MP3 or WMA music files has already been connected beforehand if the input source for the timer is set to USB.

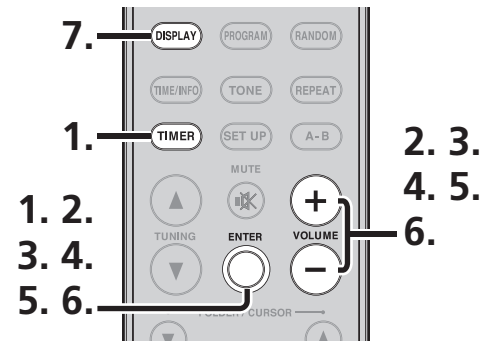

1. Press the TIMER button twice, select "TIMER," and then press the ENTER button.
2. Select "ON" using the VOLUME +/- buttons while the "OFF" indicator is flashing and then press the ENTER button.
3. Set the hour setting using the VOLUME +/- buttons while the hour indicator is flashing and then press the ENTER button.



4. Set the minute setting using the VOLUME +/- buttons while the minute indicator is flashing and then press the ENTER button.
5. Set the input source for the timer using the VOLUME +/- buttons while the input source is flashing and then press the ENTER button.



6. Set the activation time for the timer using the VOLUME +/- buttons and then press the ENTER button. This ends timer setup. The set time can be selected from 30 to 90 minutes in 10 minute intervals.

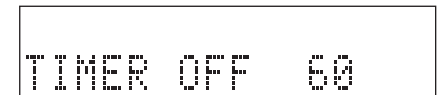

- Cancel the timer by selecting "OFF" in Step 2. above. This will cancel the timer and cause the (⏻) indicator on the display panel to go out.
7. Check the timer setting by pressing the DISPLAY button on the remote controller. The display shows the following each time the DISPLAY button is pressed.

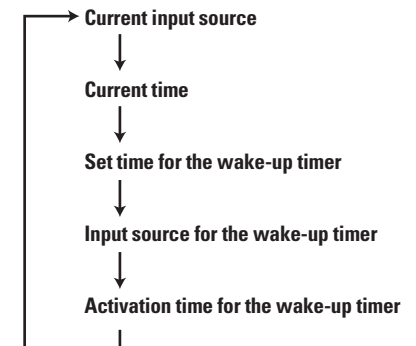

NAMES AND FUNCTIONS
 BASIC CONNECTIONS
 BASIC OPERATIONS
 BASIC SETTINGS
 PRACTICAL CONNECTIONS
 ADVANCED OPERATIONS
 IF YOU EXPERIENCE PROBLEMS
 MISCELLANEOUS

BASIC SETTINGS

SETTING THE SLEEP TIMER

This function automatically places this unit in standby mode when the specified time arrives.

Note:

The sleep timer cannot be used to place the power of external devices connected to the unit in standby mode.

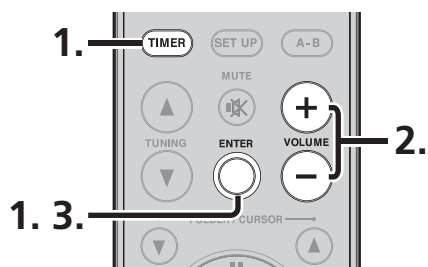

- Press the **TIMER** button three times, select "SLEEP OFF," and then press the **ENTER** button.
- Select the time to be set using the **VOLUME +/-** buttons while the "OFF" indicator is flashing.
- End sleep timer setup by pressing the **ENTER** button.
 - A time of up to 240 minutes can be set.
 - Select "OFF" in Step 2. to cancel the timer. This will cancel the sleep timer and cause the **SLEEP** indicator on the display panel to go out.
 - The sleep timer is canceled if the power of this unit is put in standby mode.

ADJUSTING THE TONE

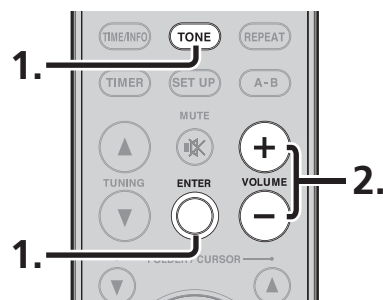

ADJUSTING THE TREBLE

- Select "TREBLE" by pressing the **TONE** button.
- Adjust the treble using the **VOLUME +/-** buttons. (-10 dB to +10 dB)

ADJUSTING THE BASS

- Select "BASS" by pressing the **TONE** button.
- Adjust the bass using the **VOLUME +/-** buttons. (-10 dB to +10 dB)

ADJUSTING LEFT-RIGHT BALANCE

- Select "BALANCE" by pressing the **TONE** button.
- Adjust the left-right balance using the **VOLUME +/-** buttons. (L (left) +6 dB ~ CENTER ~ R (right) +6 dB)

CHANGING THE BRIGHTNESS OF THE DISPLAY PANEL

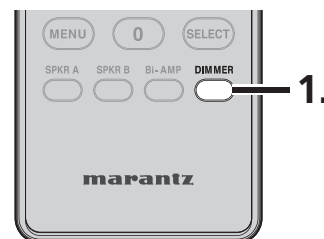

WHEN POWER IS ON

- Press the **DIMMER** button on the remote controller.
 - The brightness of the display panel switches among three levels each time the **DIMMER** button is pressed.



SETTING ECO MODE

When ECO mode is selected, the unit enters a low-power consumption mode in which nothing is displayed on the display panel during standby mode.

Standby power consumption: 2.8W or less
When the display panel is off: 0.6W or less

- While the unit's power is **ON**, press the **ON/STANDBY** button while holding down the **ENTER** button on the front panel.



- Select **ECO ON** using the **◀▶** buttons on the front panel. (Default is OFF)



- End setup by pressing the **ENTER** button on the front panel.
 - If you want to restore original settings, select **ECO OFF** in Step 2. and press the **ENTER** button.

Note:

When **ON** is selected for **ECO** mode, remote control settings (See page 17) and reset (See page 31) cannot be performed.

PRACTICAL CONNECTIONS

REMOTE CONTROL CONNECTION

- The REMOTE IN jack is intended for connecting devices equipped with a remote control connector such as a Marantz DVD player.
- The unit can be controlled using the remote sensor of a Marantz DVD player connected to the unit. Be sure to set "IR=DISABLE" when controlling in this way.

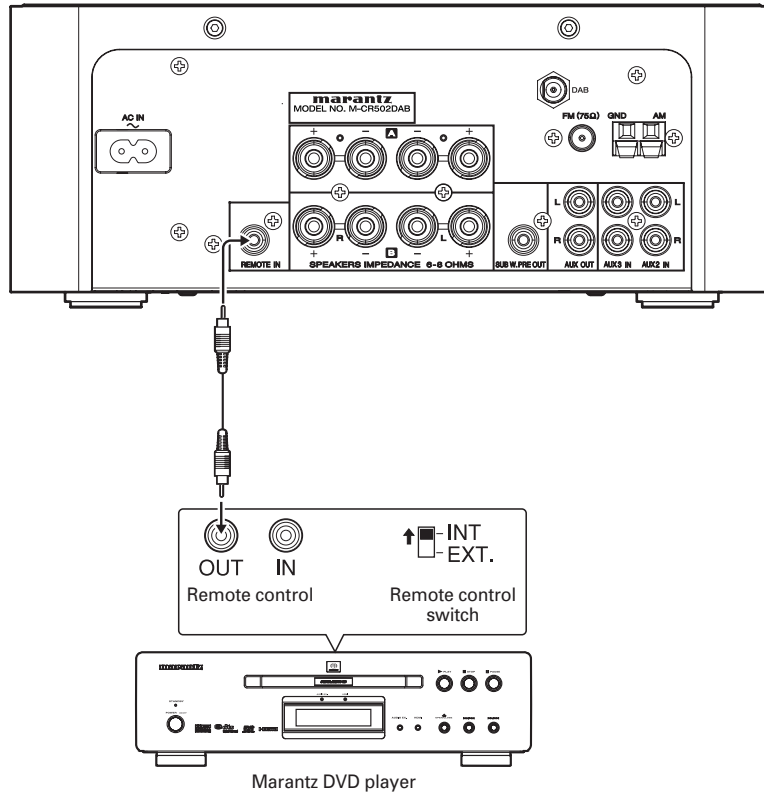

SETTING THE REMOTE CONTROL

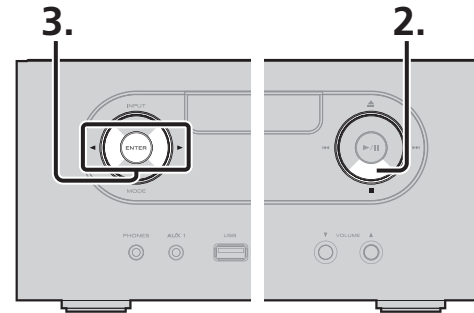

1. Put the power of the unit into standby mode.

2. Turn on the power while holding down the **■** button.

IR = ENABLE

3. Select "IR=DISABLE" using the ◀▶ buttons and then press the ENTER button.

IR = DISABLE

- The unit cannot be controlled using the remote controller while "IR=DISABLE" is set.
- To restore original settings, repeat Steps **1.** and **2.**, select "IR=ENABLE" and press the ENTER button.

Note:

When making this remote control connection, be sure to set the remote control switch, located on the rear panel of the device that is connected to the unit, to INT.

ADVANCED OPERATIONS

USING CD AND USB DEVICES EASILY

Note:

When performing these operations, be sure to put the remote controller into CD/USB mode by pressing its CD or USB button.

RANDOM PLAY

Tracks recorded on a CD or USB device may be played in random order.



Start random play by pressing the RANDOM button on the remote controller during playback or while playback is stopped.



Cancel random play by pressing the RANDOM button again.



REPEAT PLAY

Repeat play settings can be made during playback or while playback is stopped.

• CD

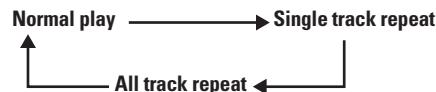

• MP3/WMA



CD SINGLE TRACK REPEAT

Single track repeat play results when the REPEAT button on the remote controller is pressed once.

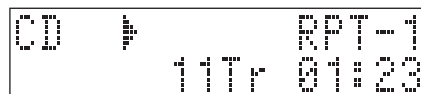

CD ALL TRACK REPEAT

All track repeat play results when the REPEAT button on the remote controller is pressed twice.

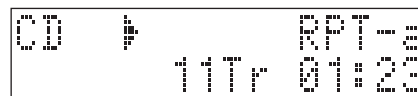

MP3/WMA SINGLE TRACK REPEAT

MP3/WMA single track repeat play results when the REPEAT button on the remote controller is pressed while playing an MP3/WMA track.



MP3/WMA FOLDER REPEAT

Repeat play of all MP3/WMA music files in a folder results when the REPEAT button on the remote controller is pressed twice.



MP3/WMA ALL TRACK REPEAT

Repeat play of all MP3/WMA music files results when the REPEAT button of the remote controller is pressed three times.



A-B REPEAT PLAY

- Repeatedly play your favorite section of a CD.

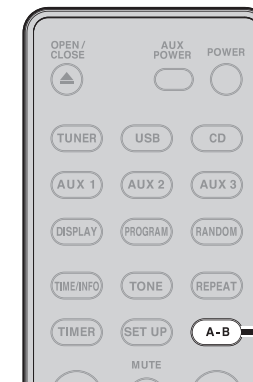

1. Press the A-B button on the remote controller at the point you want repeat play to start.



2. Repress the A-B button on the remote controller at the point you want repeat play to end.

Once settings are complete, the unit returns to the repeat start point and repeatedly plays the section between point A and B.

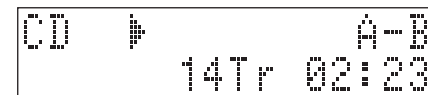

Notes:

- When playing MP3/WMA files, this function is only effective when both the start point and end point are inside the same music file.
- Cancel A-B repeat play by pressing the A-B button on the remote controller during A-B repeat play.
- A-B repeat play is not available when playing music stored on a USB device.

LISTENING TO TRACKS IN A SPECIFIED ORDER

- Your favorite tracks among those recorded on a CD or located in a given MP3/WMA music file can be played in your favorite order.
- Up to 40 tracks can be specified.
- Be sure to specify track order while playback is stopped.
- No more than 999 file numbers can be registered for USB program mode.

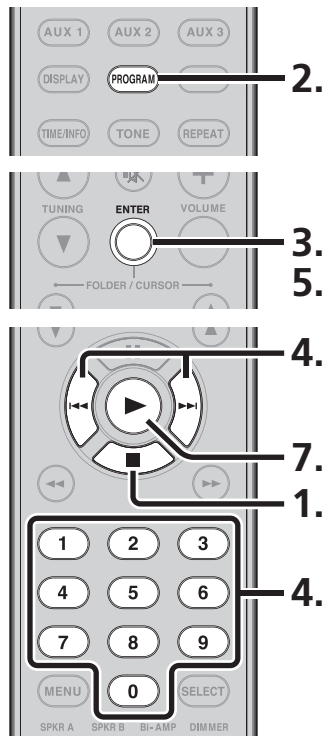

- Stop CD or MP3/WMA playback by pressing the ■ button on the remote controller.
- Press the PROGRAM button on the remote controller.



- Press the ENTER button on the remote controller.

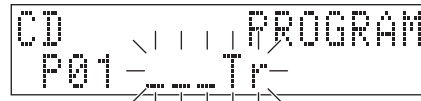

- Enter the track number that you want to program using the ◀▶ or numeric buttons on the remote controller.



- Confirm by pressing the ENTER button on the remote controller.

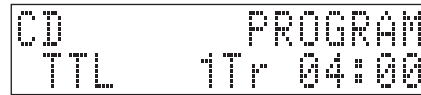

- Enter track numbers by repeating Steps 4. and 5.

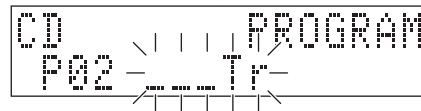

- Enter track numbers by repeating Steps 4. and 5.

- To complete program settings, press the ENTER button on the remote controller.



The total time of specified tracks is displayed.

- Press the ▶ button on the remote controller or the ▶/■ button on the unit to play your favorite specified track.

Note:

The specified track order is canceled upon reset or when the tray is opened or closed.

CANCELING SPECIFIED TRACKS

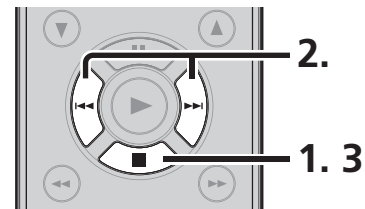

- Press the ■ button while a program is playing to stop playback of a track and put the unit into program input standby status.
- Select the program number that you want to delete using the ◀▶ or numeric buttons on the remote controller.
- Cancel the specified program number by pressing the ■ button.
 - All specified programs can be canceled by holding down the ■ button for 3 seconds during program input standby status.

Note:

In USB program mode, specific program numbers cannot be deleted. Delete all programs by pressing the ■ button for 3 or more seconds.

CHANGING THE TRACKS REGISTERED FOR PROGRAM PLAY

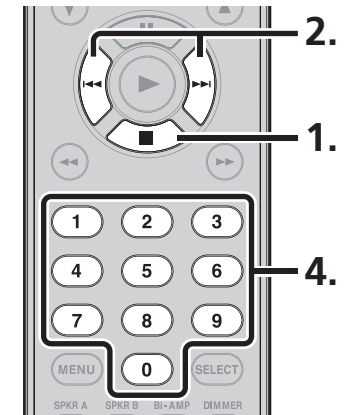
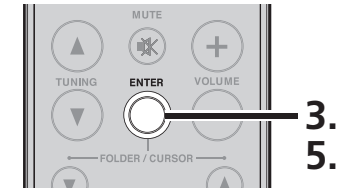

- Press the ■ button while a program is playing to stop playback of a track and put the unit into program input standby status.



- Select the program number that you want to change using the ◀▶ or numeric buttons on the remote controller.



ADVANCED OPERATIONS

- Press the ENTER button on the remote controller.

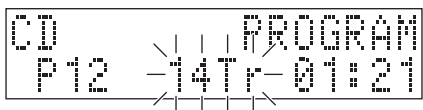

- You can cancel program changes by pressing the ENTER button on the remote controller again at this time.

- Enter your favorite track number using the numeric buttons on the remote controller.

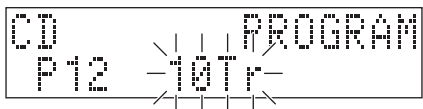

- Complete program changes by pressing the ENTER button on the remote controller.



SWITCHING THE DISPLAY ON THE DISPLAY PANEL

The display on the display panel can be switched by pressing the TIME/INFO button on the remote controller while playing a music CD or music MP3/WMA file.

MUSIC CDS



- Information displayed on the display panel changes as given below each time the TIME/INFO button is pressed.

- Elapsed time of the track



- Remaining time of the track



- Total running time of the CD



- Remaining time of the CD



MP3/WMA MUSIC FILES

- Information displayed on the display panel changes as given below each time the TIME/INFO button is pressed.

- Scroll screen



- Elapsed track time



- Remaining track time



- File name



- Track name



- Artist's name



- Album name



- Year of creation



- Comment



Note:

The characters that can be displayed are all alphanumeric characters and some special symbols (such as - and !). All other character information appears as garbage characters.

ADVANCED OPERATIONS

ABOUT MP3/WMA FILES

- The standard specification supported by this CD receiver is “MPEG-1 Audio Layer-3” (with a sampling frequency of 32, 44.1 or 48 kHz.) This CD receiver does not support other standards such as “MPEG-2 Audio Layer-3,” “MPEG-2.5 Audio Layer-3,” MP1, or MP2.
- Generally, sound quality improves as the bit rate increases. The bit rate supported by MP3 ranges from 32 to 320 kbps, while that for WMA is 192 kbps or lower. We recommend that you use MP3/WMA files recorded at a bit rate of 128 kbps or higher with this CD receiver.
- Be absolutely sure that MP3/WMA files have the extension “.MP3” or “.WMA.” Files with an extension other than “.MP3” or “.WMA” and files without an extension cannot be played. (However, when using a Macintosh PC it is possible to play an MP3 file by adding the “.MP3” extension to the end of a file name consisting of 30 or fewer half-space uppercase English letters and recording on a CD-R/RW.)
- A play list is not supported.
- During USB playback
The maximum number of files and folders that can be displayed by this unit is limited to 255, respectively.
This does not include files and folders that cannot be played by this unit.
- During CD playback
The number of files, including folders, that can be displayed by this unit, is limited to a total of 255.
- The unit can display folder names and file names consisting of up to 30 characters.
- Japanese language display is not supported in the case of ID3 tag information and file names displayed when playing MP3 data.
- The unit only supports MP3 ID3-Tag Version 1.
- Sometimes the time is not displayed correctly when playing a variable bit rate file.
- Be sure to use ISO9660 Mode 1 or Mode 2 as the format when writing data to a CD-R or CD-RW. Data written later can also be played because multisession discs are supported.
- MP3/WMA files recorded using packet writing cannot be played.
- Reading track information may take time in some cases depending on the state of the data that has been recorded.
- Only CD-DA disks formatted for music can be played for CD-DAs formatted for music and enhanced CDs or mixed CDs that contain a mix of MP3/WMA files.
- WMA DRM playback (copyright protection) is not supported.

CONVENIENT FUNCTIONS FOR LISTENING TO RADIO BROADCASTS

The unit can store up to 30 FM and 20 AM stations, as presets.
Two methods are available for storing broadcast stations: “automatic storing” and “manual storing”.

Note:

When performing these operations, be sure to put the remote controller into TUNER mode by pressing its TUNER button.

AUTOMATICALLY STORING BROADCAST STATIONS (AUTO PRESET)

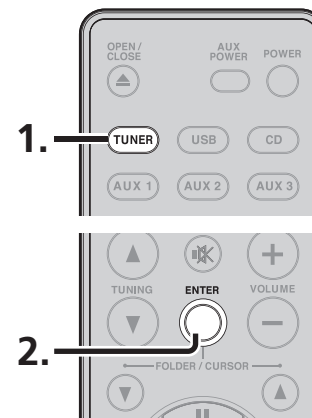
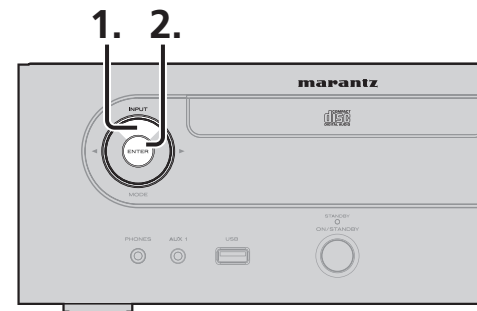

1. Select TUNER AM or TUNER FM by pressing the INPUT button on the unit or the TUNER button on the remote controller.
2. Hold down the ENTER button for 3 or more seconds.
 - Broadcast stations that can be received are automatically selected and stored beginning from the lowest frequency.

MANUALLY STORING BROADCAST STATIONS (MANUAL PRESET)

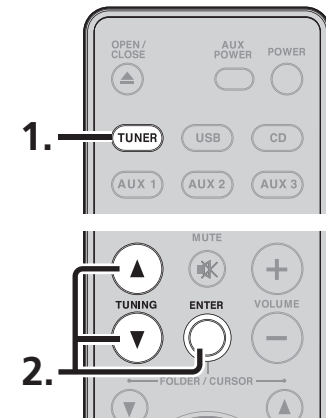
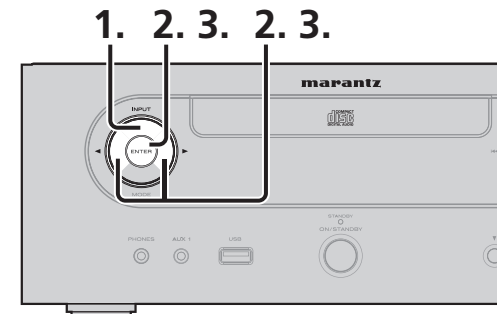

1. Select TUNER AM or TUNER FM by pressing the INPUT button on the unit or the TUNER button on the remote controller.

ADVANCED OPERATIONS

- Select a frequency that can be received using the ◀▶ buttons on the unit or the TUNING ▲▼ buttons on the remote controller and then press the ENTER button.



- Select the preset number in which to register the station using the ◀▶ button or the numeric keys on the remote controller, and then press the ENTER button.



Note:

Press the ENTER button within 4 seconds after selecting the preset number. Registration is canceled if the ENTER button is not pressed within 4 seconds.

CALLING UP REGISTERED BROADCAST STATIONS

- Call up a preset number using the ◀▶ buttons on the unit or remote controller.
 - Registered stations can also be called up using the numeric keys on the remote controller.

DELETING REGISTERED PRESET NUMBERS

- Preset numbers can be erased by calling up the number you want to erase and then pressing the ■ button on the unit.
- If you want to erase all preset numbers, be sure to hold down the ■ button on the unit for 3 or more seconds.



NAMING REGISTERED BROADCAST STATIONS

Note:

Names can only be given to AM and FM broadcast stations.

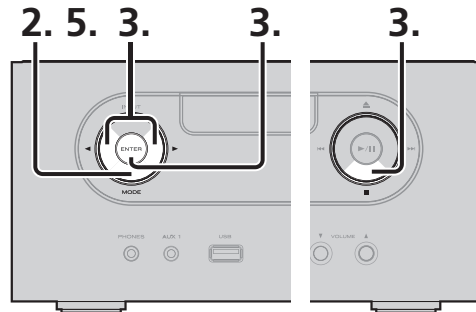

- Call up the broadcast station you want to give a name to.
- Press the MODE button on the unit.
- Specify the name using alphanumeric letters (A to Z) and numbers (0 to 9) using the ◀▶ buttons and confirm using the ENTER button.
 - Select the space located between “Z” and “0” to enter a space.
 - Press the ■ button on the unit to erase the last character entered.
 - Hold down the ■ button on the unit for 3 or more seconds to erase all characters.

- Repeat Steps 1. through 3. about until you have entered all characters.
- Register the name by pressing the MODE button.

FM RECEPTION MODE

When FM is selected as the tuner band, it may sometimes be difficult to receive broadcasts in stereo when the signal is weak. In such cases, be sure to switch the FM reception mode to mono. This will help alleviate noise and make the frequency easier to listen to.

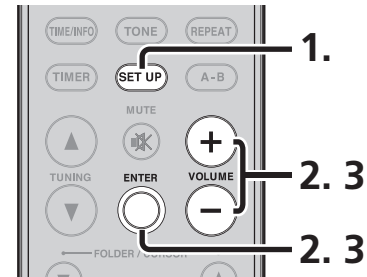
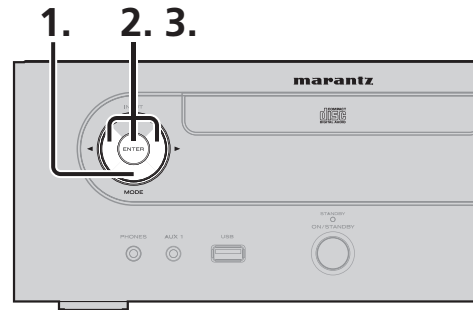

- Press the MODE button on the unit for 3 or more seconds or the SET UP button on the remote controller.
- Select “FM STEREO/MONO” from the menu by pressing the ◀▶ buttons on the unit or the VOLUME buttons on the remote controller and then press the ENTER button.



- Select “MONO” using the ◀▶ buttons on the unit or the VOLUME buttons on the remote controller and then press the ENTER button.



- The default setting is STEREO.

Note:

FM reception mode settings can only be made when the FM band is selected for the tuner.

ADVANCED OPERATIONS

RDS (RADIO DATA SYSTEM)

- RDS (works only on the FM band) is a broadcasting service that allows stations to send additional information along with the regular radio program signal.
- The following three types of RDS information can be received by the unit.

PROGRAM TYPE (PTY)

- PTY identifies the type of RDS program.
- The program types and their displays are as follows:

DISPLAY	PROGRAMME TYPE
POP M	Pop Music
ROCK M	Rock Music
EASY M	Easy Listening Music
LIGHT M	Light Classical Music
CLASSICS	Serious Classical Music
NEWS	News
AFFAIRS	Current Affairs
INFO	Information
SPORT	Sport
EDUCATE	Education
DRAMA	Drama
CULTURE	Culture
SCIENCE	Science
VARIED	Varied
OTHER M	Other Music
WEATHER	Weather
FINANCE	Finance
CHILDREN	Children's Programmes
SOCIAL	Social Affairs
RELIGION	Religion
PHONE IN	Phone In
TRAVEL	Travel
LEISURE	Leisure
JAZZ	Jazz Music
COUNTRY	Country Music
NATION M	National Music
OLDIES	Oldies Music
FOLK M	Folk Music
DOCUMENT	Documentary

TRAFFIC PROGRAM (TP)

- TP identifies programs that carry traffic announcements.
- This allows you to easily receive updates on the latest traffic conditions in your area before you leave home.

RADIO TEXT (RT)

- RT allows the RDS station to send text messages that appear on the display.

Notes:

- *The operations performed by pressing the FOLDER/CURSORS button given below will not function in areas in which there are no RDS broadcasts.*
- *RDS-related settings can only be made when the FM band is selected for the tuner.*

RDS SEARCH

Use this function to automatically tune to FM stations that provide RDS service.

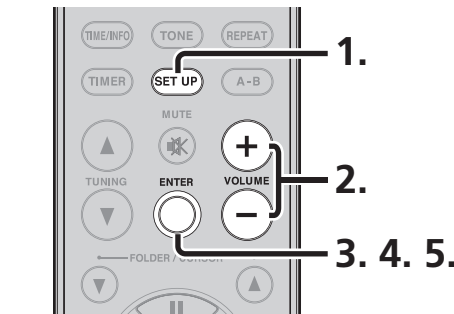
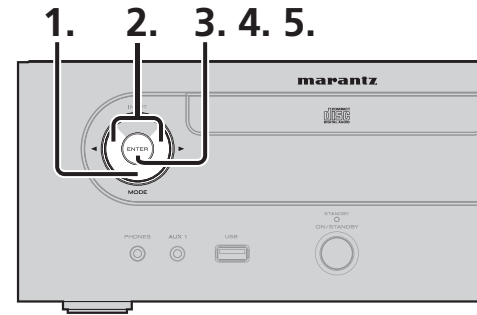

1. Press the MODE button on the front panel for 3 or more seconds or the SET UP button on remote controller while in FM mode.
2. Press the ◀▶ buttons on the front panel or the VOLUME button on the remote controller to select "RDS."



3. Press the ENTER button to select the RDS function. "RDS Search" is displayed.

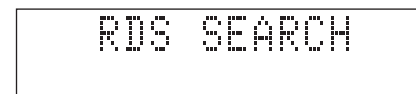

4. Press the ENTER button to set select RDS search selection mode.



5. Repress the ENTER button. RDS search starts automatically and the RDS indicator flashes.
 - If no RDS station is found, all bands being received are searched.
 - When a broadcast station is found, that station's name appears on the display.
6. If no RDS station is found after searching all frequencies, "NO RDS" is displayed.



NAMES AND FUNCTIONS
BASIC CONNECTIONS
BASIC OPERATIONS
BASIC SETTINGS
PRACTICAL CONNECTIONS
ADVANCED OPERATIONS
IF YOU EXPERIENCE PROBLEMS
MISCELLANEOUS

ADVANCED OPERATIONS

PTY SEARCH

- Use this function to find RDS stations broadcasting a designated program type (PTY).
- For a description of each program type, refer to "Program Type (PTY)".

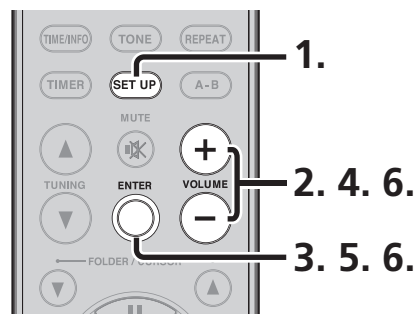
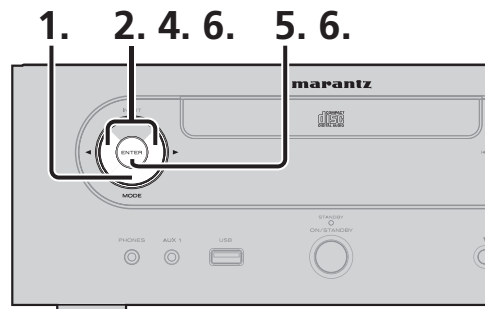

1. Press the MODE button on the front panel for 3 or more seconds or the SET UP button on the remote controller while in FM mode.
2. Press the ◀▶ buttons on the front panel or the VOLUME button on the remote controller to select "RDS."



3. Press the ENTER button to select the RDS function.

4. Press the ◀▶ buttons on the front panel or the VOLUME button on the remote controller to select "PTY Search."

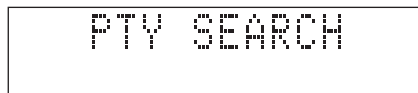

5. Press the ENTER button to set PTY search selection mode.



6. Press the ◀▶ buttons on the front panel or the VOLUME button on the remote controller to call up the desired program type.
 - When receiving an RDS station, its program type is displayed first.
 - When not receiving an RDS station, "PTY" flashes.

7. Press the ENTER button to set PTY search selection mode.



8. Press the ENTER button. RDS search starts automatically and the RDS indicator flashes.
 - If no station broadcasting the designated program type is found, all bands being received are searched.
 - The station name is displayed on the display after the search ends.

9. If no station broadcasting the designated program type is found after searching all frequencies, "NO programme" is displayed.



TRAFFIC PROGRAM SEARCH (TP SEARCH)

Use this function to find RDS stations broadcasting a traffic program (TP).

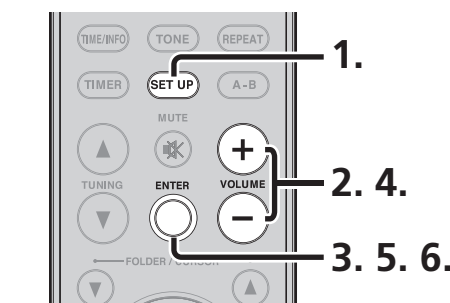
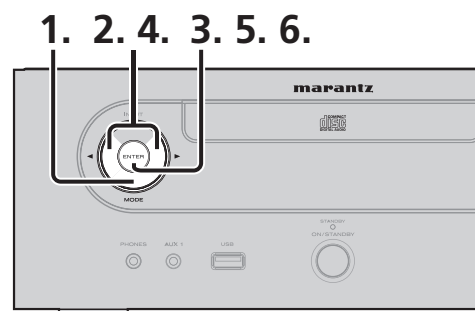

1. Press the MODE button on the front panel for 3 or more seconds or the SET UP button on the remote controller while in FM mode.
2. Press the ◀▶ buttons on the front panel or the VOLUME button on the remote controller to select "RDS."



3. Press the ENTER button to select the RDS function.

4. Press the ◀▶ buttons on the front panel or the VOLUME button on the remote controller to select "TP Search."

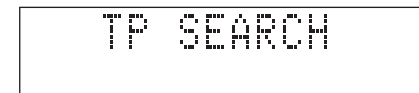

5. Press the ENTER button to set TP search selection mode.



6. Repress the ENTER button. The RDS search starts automatically and the RDS indicator flashes.
 - If no TP station is found, all bands being received are searched.
 - The station name is displayed on the display after the search ends.

7. If no station broadcasting the designated program type is found after searching all frequencies, "NO programme" is displayed.



ADVANCED OPERATIONS

RT (RADIO TEXT)

1. 2. 4. 6. 3. 5. 7.

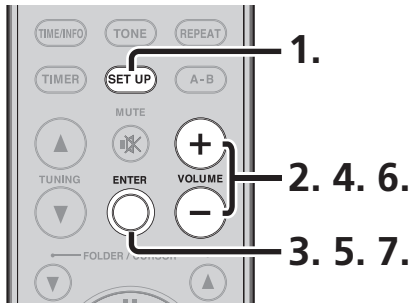
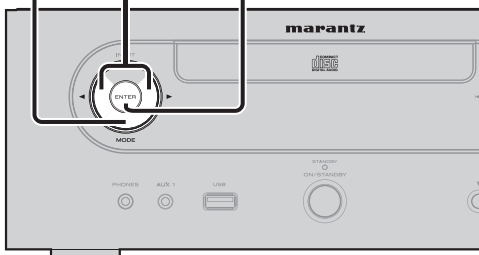

1. Press the MODE button on the front panel for 3 or more seconds or the SET UP button on the remote controller while in FM mode.
2. Press the ◀▶ buttons on the front panel or the VOLUME button on the remote controller to select "RDS."

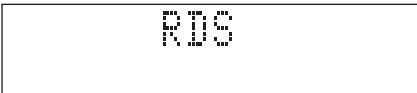

3. Press the ENTER button to select the RDS function.

4. Press the ◀▶ button on the front panel or the VOLUME button on the remote controller to display "RT ON/OFF."



5. Press the ENTER button to set RT ON/ OFF mode.
6. Press the ◀▶ button on the front panel or the VOLUME button on the remote controller to select "RT ON" or "RT OFF."



7. Repress the ENTER button to set whether to enable or disable the RADIO TEXT function.
 - If no text data is being broadcast, "NO TEXT DATA" is displayed.

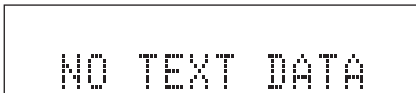

CT (CLOCK TIME)

- You can set the clock time automatically from an RDS station broadcasting Clock Time (CT) information. If "CT ON" is set, the unit automatically sets its clock to match the Clock Time information being received.

1. 2. 4. 6. 3. 5. 7.

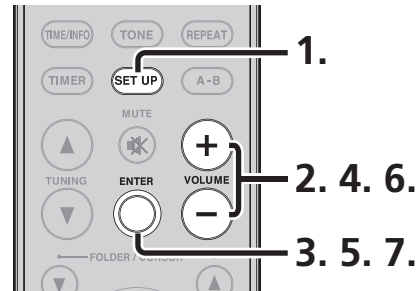
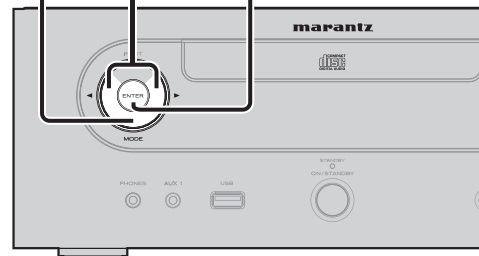

1. Press the MODE button on the front panel for 3 or more seconds or the SET UP button on the remote controller while in FM mode.
2. Press the ◀▶ button on the front panel or the VOLUME button on the remote controller to select "RDS".

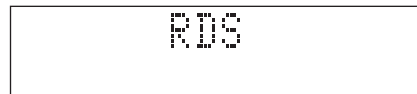

3. Press the ENTER button to select the RDS function.

4. Press the ◀▶ buttons on the front panel or the VOLUME button on the remote controller to display "CT ON/OFF."



5. Press the ENTER button to set CT ON/ OFF mode.
6. Press the ◀▶ buttons on the front panel or the VOLUME button on the remote controller to select "CT ON" or "CT OFF."

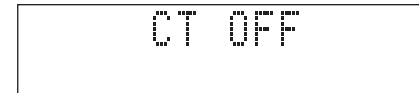
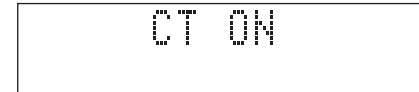

7. Repress the ENTER button to set whether to enable or disable the Clock Time function.
 - If you live close to the border with another country, Clock Time information may be received from a radio station in another time zone.
 - In this case you should select "CT OFF."
 - In this mode, "CT" data is received, but the time on the unit is not changed.

ADVANCED OPERATIONS

SWITCHING RDS INFORMATION DISPLAY

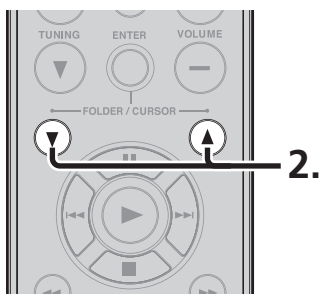

1. Use the procedure described at "AUTO PRESET," "MANUAL PRESET" or "CALLING UP REGISTERED BROADCAST STATIONS" to tune in the frequency of an RDS station.
2. Press the FOLDER/CURSOR button to switch the RDS information shown.
 - The display switches as shown below each time the FOLDER/CURSOR button is pressed.

- ① STATION NAME:
Displays the station name if the search mode is set to PRESET and a name has been registered for the station.

```
FM108.00MHz ch05
MARANTZ
```

- ② PS:
Displays the program service name and frequency of the station being received.

```
FM108.00MHz ch05
PS abcdefgh TP
```

The above is an example of a case where there is TP data, but no RT data.

- ③ PTY:
Displays the program type of broadcast being received.

```
FM108.00MHz ch05
PTY NATION M
```

- ④ CT:
Displays the current time.

```
FM108.00MHz ch05
CT 18:00
```

DAB (DIGITAL AUDIO BROADCASTING)

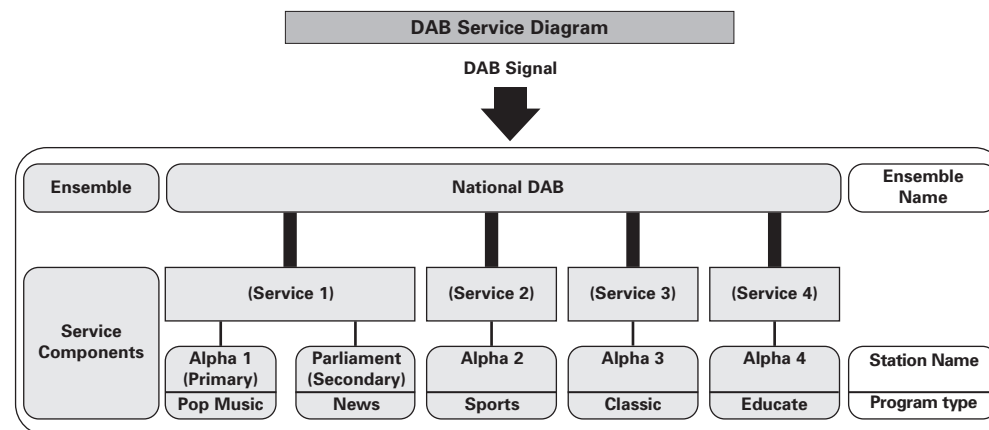

- Since the DAB system is broadcasted in digital format, DAB system can supply crystal-clear audio and stable reception even in mobile objects. DAB is a new generation radio which can provide data service and supplementary multi-media services.
- DAB broadcasts multiple services under one Ensemble that are called service components.
- Each component contains inherent programs; news, music, sports, and many more.
- Each Ensemble and service component has its label, and users can recognize a current broadcasting station and service contents by using the label.
- The main service component is broadcast as Primary while the others are broadcast as Secondary.
- Also rich character information is serviced through Dynamic Labels; song title, artist composer etc.

LISTENING TO DAB BROADCAST

Before listening to a DAB broadcast, check that the DAB antenna is connected to the unit.

1. Select DAB as the input source using the INPUT button on the unit or the TUNER button on the remote controller.

Note:

- When selecting DAB for the first time, the unit automatically selects the receivable broadcast stations. This selection takes about 90 seconds to finish.
- When changing the input source with the INPUT button on the unit, be sure to put the remote controller into TUNER mode by pressing its TUNER button.

2. Select the broadcast station that you want with the ◀▶ buttons on the unit or the TUNING ▲/▼ buttons on the remote controller and press the ENTER button.

Note:

If the selected DAB service cannot be received, "Station not available" is displayed on the display panel.

SELECTING A PRIMARY SERVICE THAT INCLUDES A SECONDARY SERVICE

1. Select the broadcast station that you want with the ◀▶ buttons on the unit or the TUNING ▲/▼ buttons on the remote controller.
2. When a Primary service that includes a Secondary service is selected, ">" is displayed.

3. Press the ENTER button.
The SECONDARY indicator flashes for 5 seconds and then turns off.

SELECTING A SECONDARY SERVICE

1. Select the broadcast station that you want with the ◀▶ buttons on the unit or the TUNING ▲/▼ buttons on the remote controller.
2. When a Secondary service is selected, "<<" is displayed.

3. Press the ENTER button.
The SECONDARY indicator lights.

DAB SET UP MODE

Note:

DAB set up mode can only be selected when DAB input is selected.

In DAB set up mode, "Sort Mode", "Auto Scan", "Tuning aid" or "DRC Value" can be set.

1. Press the MODE button on the unit for 3 or more seconds, or press the SET UP button on the remote controller.
2. Select "DAB SET UP" in the menu with the ◀▶ buttons on the unit or the VOLUME button on the remote controller and press the ENTER button.
3. Select the item that you want in the menu with the ◀▶ buttons on the unit or the VOLUME button on the remote controller and press the ENTER button.

SORT MODE

The DAB stations can be sorted by Alphanumeric or Ensemble.

1. Select "Sort Mode" in DAB set up mode and press the ENTER button.
2. Select "Alphanumeric" or "Ensemble" and press the ENTER button.

AUTO SCAN

1. Select "Auto Scan" in DAB set up mode and press the ENTER button.
2. Select "Full Scan" or "Local Scan" with the ◀▶ buttons on the unit or the VOLUME button on the remote controller and press the ENTER button.

Full Scan: Scans the entire Band III frequency range. When the scan detects a new station, it is added to the DAB channel list.

Local Scan: Scans between 218.640 MHz and 229.072 MHz.

TUNING AID

You can adjust the antenna to the best reception position for the channel to which you want to listen.

1. Select "Tuning aid" in DAB set up mode and press the ENTER button.
2. Select the station for which you want to perform Tuning aid with the ◀▶ buttons on the unit or the VOLUME button on the remote controller and press the ENTER button.
3. Install the DAB antenna in the position with the most > marks on the display.
4. Press the ENTER button to complete Tuning aid.

DRC VALUE

The DRC (Dynamic Range Control) function lets you change the dynamic range of the received sound depending on the content of the broadcast so that the sound is easier to hear even when the volume is low.

1. Select "DRC Value" in DAB set up mode and press the ENTER button.
2. Select "OFF", "1" or "2" with the ◀▶ buttons on the unit or the VOLUME button on the remote controller and press the ENTER button.

OFF: DRC OFF mode

1: DRC medium level

2: DRC maximum level

MANUALLY PRESETTING DAB BROADCAST STATIONS

1. Select "DAB" with the INPUT button on the unit or the TUNER button on the remote controller.
2. Select the broadcast station that you want to preset with the ◀▶ buttons on the unit or the TUNING ▲/▼ buttons on the remote controller and press the ENTER button.
3. Press the ENTER button again to display the preset number.
4. Enter the preset number with the ◀▶ buttons on the unit or the number buttons on the remote controller and then press the ENTER button.
 - A preset number between 1 and 99 can be registered.

SELECTING A PRESET NUMBER

1. Display the preset number that you want to select by pressing the ◀▶ buttons.

2. Press the ENTER button to start broadcasting the station that corresponds to the selected number.

ADVANCED OPERATIONS

ERASING A PRESET NUMBER

1. Display the preset number that you want to erase by pressing the ◀▶ buttons, and press the ■ button on the unit.
2. "Clear?" is displayed on the display panel.

BBC Radio 5 Live
ch03 Clear?

3. Press the ■ button on the unit within 4 seconds to erase the preset number.
- If you want to erase all the preset numbers, press the ■ button on the unit for 3 or more seconds while a broadcast is being received.

SWITCHING THE DAB INFORMATION DISPLAY

You can display information about the DAB station to which you are listening. The following information is displayed in turn each time the FOLDER/CURSOR ▲/▼ buttons on the remote controller are pressed.

- ① DLS (Dynamic Label Segment):
The text data included in the broadcast scrolls.
BBC Radio 5 Live
weekday NEWS & D
- ② Program Type:
The category of the broadcast being received is displayed.
BBC Radio 5 Live
NEWS
- ③ Ensemble Name:
The ensemble name is displayed.
BBC Radio 5 Live
BBC National DAB

- ④ Time and Date:
The current time and date are displayed.
BBC Radio 5 Live
01:01 15-07-2005
- ⑤ Audio information:
The bit rate and mode of the broadcast being received is displayed.
BBC Radio 5 Live
192Kbps STEREO
- ⑥ Channel and frequency:
The frequency is displayed.
BBC Radio 5 Live
11C 220.35MHz
- ⑦ Bit Error Rate (0-100):
The higher the figure, the better the quality of the received broadcast.
BBC Radio 5 Live
Signal Q: 100

SETTING AMP CHARACTERISTICS (SPEAKER A, B)

- Amp properties can be changed according to the location speakers are installed.
- Five types of characteristics can be selected.
- Different characteristics can be selected for Speaker A and Speaker B.

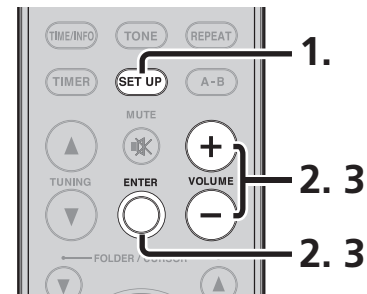
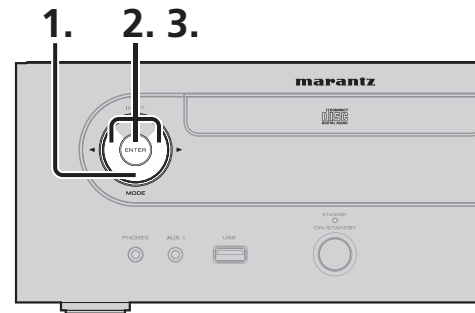

1. Press the MODE button on the unit for 3 or more seconds or the SET UP button on the remote controller.
2. Select "SPK A" or "SPK B" from the menu using the ◀▶ buttons on the unit or the VOLUME buttons on the remote controller and then press the ENTER button.

SPK A

3. Select the desired characteristics from the list below using the ◀▶ buttons on the unit or the VOLUME buttons on the remote controller and then press the ENTER button.
 - FLAT
 - RESPONSE 1
 - RESPONSE 2
 - RESPONSE 3
 - RESPONSE 4

FLAT

- The default setting is FLAT.

A description of characteristics is given below.

- **FLAT**
Properties are flat. This enhances bass frequencies when speakers are placed directly on furniture or on a rack. If you feel that there is too much bass, select your favorite properties from among RESPONSE1 to RESPONSE4.
- **RESPONSE 1**
Cuts low frequencies 60 Hz or under by -12 dB/oct.
- **RESPONSE 2**
Cuts low frequencies 100 Hz or under by -12 dB/oct.
- **RESPONSE 3**
Cuts low frequencies 60 Hz or under by -12 dB/oct. Also, raises the 400 Hz region by 3 dB.
- **RESPONSE 4**
Cuts low frequencies 100 Hz or under by -12 dB/oct. Also, raises the 400 Hz region by 3 dB.

LISTENING TO MUSIC USING BI-WIRING

Bi-wiring can be used to connect speakers using two pairs of speaker cables to connect the unit and speaker system.

Before making connections, check that the speaker system supports bi-wiring.

What is Bi-Wiring?

Bi-wiring is a technique used to improve sound quality where separate speaker cables are used to connect to terminals for the low-end and mid-range frequencies.

This connection method can help eliminate interference in the mid-range caused by back-EMF generated by the speaker unit used for the low-end.

Note:

Be sure to set the same filter for both Speaker A and Speaker B when listening to music on speakers connected using bi-wiring. (See "SETTING AMP CHARACTERISTICS" on page 27)

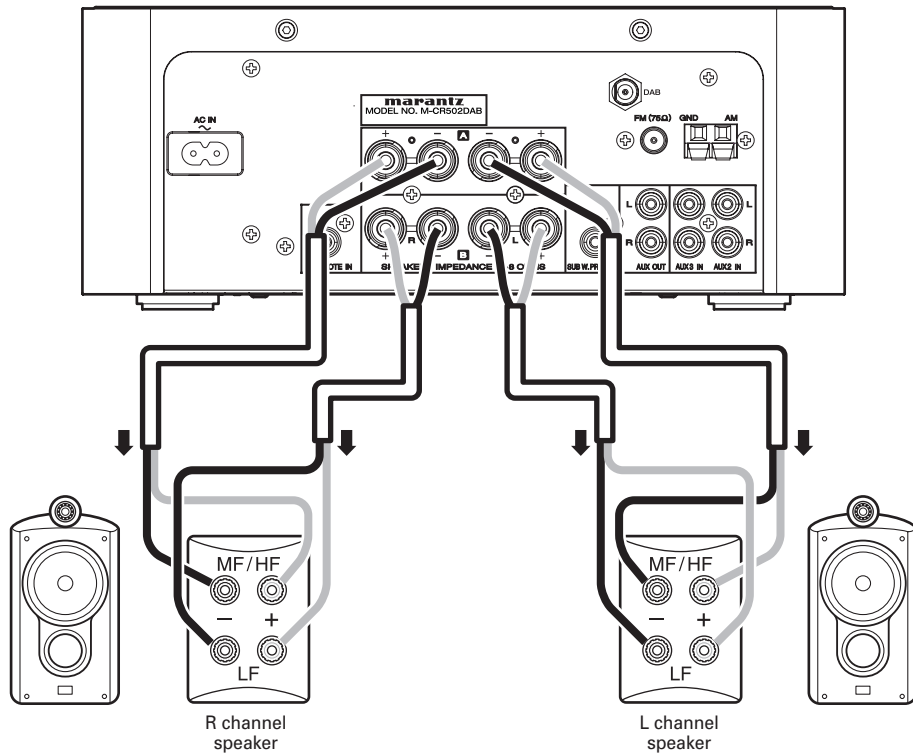

Note:

Be sure to remove the short plate connecting the LF and MF/HF connectors on the speaker. Failure to do so may result in fire and/or damage to the equipment during use.

SETTING SPEAKER OUTPUT

- Set the speaker output of the unit to BI-AMP.
- Maximum amp output switches from 50 W to 25 W per channel.
- BI-AMP mode is canceled for speaker output if SPKR A or SPKR B is set.
- The default setting is SPKR A.

Note:

Set the audio volume appropriately before making speaker settings.

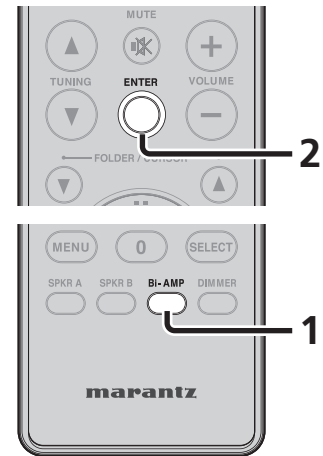

1. Press the BI-AMP button on the remote controller.

Note:

The display returns to normal if the BI-AMP button on the remote controller is pressed for 3 or more seconds.

2. Press the ENTER button. The display changes from flashing to lit.

ADVANCED OPERATIONS

LISTENING TO MUSIC IN TWO LOCATIONS USING A MULTI-DRIVE CONNECTION

You can listen to music in different rooms using this unit with two pairs of speaker systems.

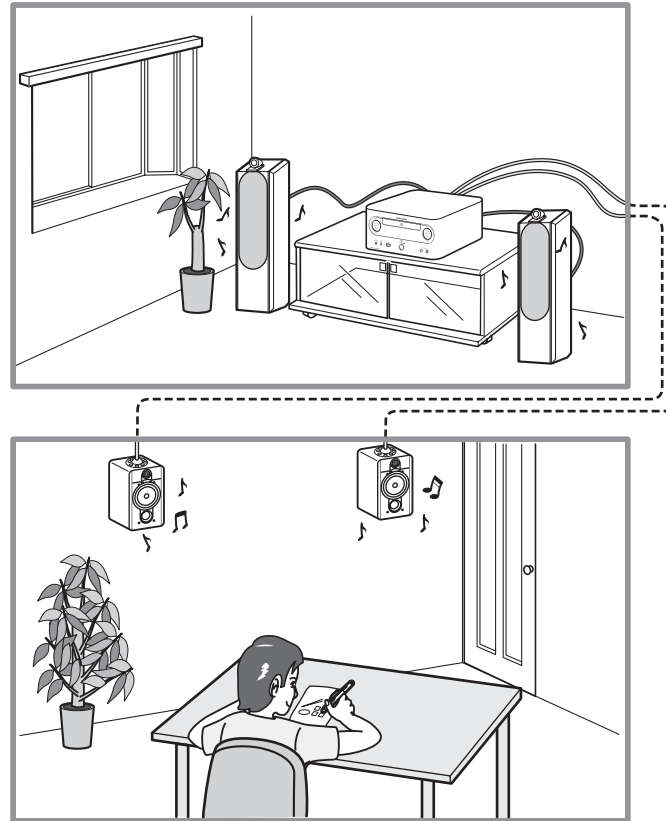
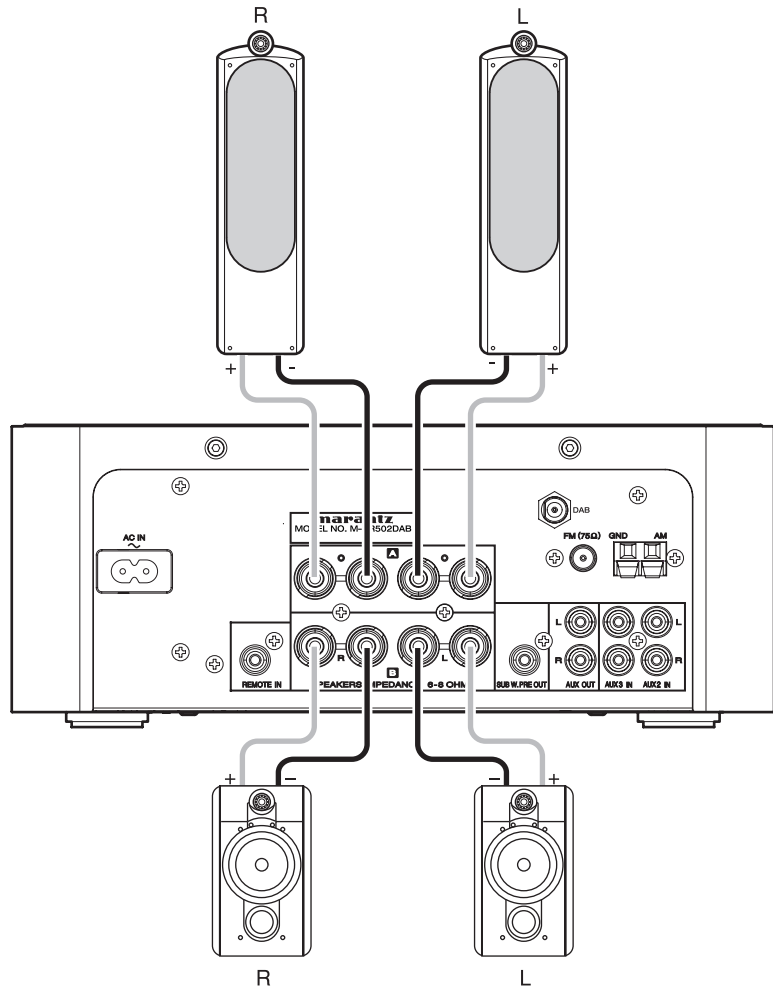

SETTING SPEAKER OUTPUT

- Set the speaker output of the unit to BI-AMP.
- Maximum amp output switches from 50 W to 25 W per channel.
- BI-AMP mode is canceled for speaker output if SPKR A or SPKR B is set.
- The default setting is SPKR A.

Note:

Set the audio volume appropriately before making speaker settings.

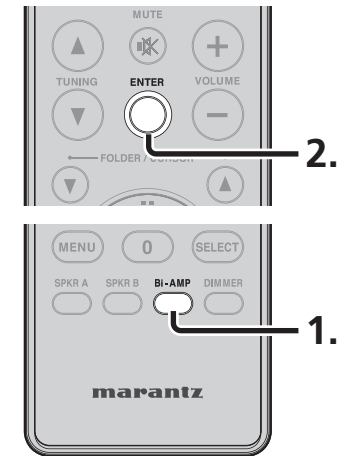

1. Press the BI-AMP button on the remote controller.

Note:

The display returns to normal if the BI-AMP button on the remote controller is pressed for 3 or more seconds.

2. Press the ENTER button.
The display changes from flashing to lit.

ADJUSTING THE AUDIO LEVEL BALANCE BETWEEN SPEAKERS A AND B

With the output of Speaker A fixed, the audio level of Speaker B can be adjusted within the range -6 dB to +6 dB.

1. Press the MODE button on the unit for 3 or more seconds or the SET UP button on the remote controller.
2. Select "VOLOFFSET" from the menu using the ◀▶ buttons on the unit or the VOLUME buttons on the remote controller and then press the ENTER button.



3. Adjust the audio level for Speaker B using the ◀▶ buttons on the unit or the VOLUME buttons on the remote controller, and then press the ENTER button.



PERFORMING RESET

- All settings can be returned to default status.
- Reset is selected on the unit.

1. Put the power of the unit into standby mode.
2. Press the ON/STANDBY button while holding down the MODE button. "RESET?" will flash on the display panel at this time.



3. Press the ENTER button to confirm. "RESET COMPLETE" will be displayed on the display panel for 1 second at this time and then reset is complete.



DEFAULT STATUS

INPUT	CD
Volume	0
Dimmer	OFF
ECO MODE	OFF
Speaker settings	A
Tuner preset channels	Not set
TREBLE	0
BASS	0
BALANCE	CENTER
Clock	Not set
Wake-up timer	Not set
Sleep timer	Not set
SPK A	FLAT
SPK B	FLAT
VOLUME OFFSET	0
FM STEREO/MONO	STEREO
IR	ENABLE
RT	OFF
CT	OFF
DRC	OFF

IF YOU EXPERIENCE PROBLEMS

Be sure to check the items in the following list if you experience problems. If checking the following items does not resolve your problem, please contact the retail store where you purchased your product or your nearest Marantz Consumer Marketing or Service Center.

GENERAL

Symptom	Possible Cause	Resolution
Power does not come on. The unit enters standby mode immediately after turning on power.	The power cable is not fully plugged in.	Check that the power cable is connected correctly. (Page 10)
	The speaker cable is in contact with the unit. Or, the cable has shorted.	Check that the speaker cables are connected correctly. (Page 7)
The audio level of one of the channels is low.	Cables are not connected correctly.	Check that all cables are connected correctly.
	The left and right channels are out of balance.	Try adjusting the left-right balance. (Page 16)
The unit does not function correctly.	The unit has received a strong electric shock from an external source, such as a lightning strike or static electricity.	Unplug the power cable of the unit, wait 3 minutes, and plug the power cable back into a power outlet.
Noise from other devices in the surrounding area is being emitted.	The unit is too close to the other devices.	Separate the unit from the other devices.
Noise from the unit is being emitted.	The unit is connected to the same power outlet as a personal computer or other digital device.	Either connect to a different power outlet or connect a commercially available power filter to the unit.
The set time has been lost.	The power cable has become disconnected or the power supply has been cut off for 1 or more minutes due to a power outage or other cause.	The time is initialized if the power supply is cut off for 1 or more minutes. Reset the time. (Page 15)

REMOTE CONTROL OPERATIONS

Symptom	Possible Cause	Resolution
The unit cannot be operated using the remote controller.	You are out of the operating range of the remote controller.	Refer to the operating range for the remote controller (Page 3) and use it only inside the proper operating range.
	The receiver for remote control signals on the unit is being struck by direct sunlight or lighting.	Change the orientation of the unit so that direct sunlight or lighting does not strike it.
	The batteries are used up.	Be sure to replace with new batteries.
	IR=DISABLE has been set.	Be sure to set to IR=ENABLE. (Page 17)

CD AND USB OPERATIONS

Symptom	Possible Cause	Resolution
Cannot play a music CD.	The disc has been inserted upside down.	Be sure to play the disc with the label side facing up.
	The disc is dirty.	Refer to handling the disc. (Page 35)
	The disc is warped or scratched.	Try playing a new disc.
CD-R and CD-RW discs cannot be played.	The disc has not been finalized.	Be sure to finalize the disc using software for writing data to disc.
	There is a problem with the disc itself.	Try using discs from another disc manufacturer.
MP3 and/or WMA files cannot be played when using a USB device.	The file extension is not MP3 or WMA.	Change the file extension and try writing to the USB device again.
	The compression format is not MP3 or WMA.	Convert to MP3 or WMA format.
	The USB memory device has been destroyed.	Replace the USB memory device.
No sound is emitted from speakers even though a CD is playing.	The audio volume is not turned up.	Raise the audio volume to an appropriate level.
	The audio system is being muted.	Press the MUTE button on the remote controller.
	The input source is not set to CD.	Press the CD button on the remote controller.
	Speaker cables are not connected.	Check that speaker cables are connected correctly. (Page 7)
	Headphones are connected.	Lower the audio volume and disconnect the headphones.
	CD playback is being paused.	Press the ►/ button on the unit.
The sound skips during CD playback.	The disc is warped or scratched.	Try playing a new disc.
	The unit is installed in a location subject to vibration or shock of impact.	Place the unit in a stable location.
	The disc is dirty.	Refer to disc handling (Page 35).
	You are using a copy-controlled CD.	Marantz does not guarantee the playback of copy-controlled CDs.

IF YOU EXPERIENCE PROBLEMS

RADIO OPERATIONS

Symptom	Possible Cause	Resolution
Cannot select a broadcast station by preset number.	The unit has lost all preset information.	Register the broadcast station again.
There is a lot of noise when listening to an FM broadcast.	The signal of the broadcast station being tuned is weak or reception is poor in your area.	1. Change the orientation of the antenna. 2. Try setting the FM stereo to FM mono. (Page 22) 3. Change the FM antenna to a commercially available outdoor antenna.
Cannot automatically select FM broadcast stations.	The signal of the broadcast station being tuned is weak or reception is poor in your area.	1. Change the orientation of the simple antenna. 2. Try setting the FM stereo to FM mono. (Page 22) 3. Change the FM antenna to a commercially available outdoor antenna.
Cannot automatically select AM broadcast stations.	The AM loop antenna is not connected correctly.	Connect the loop antenna correctly.
	The signal of the AM broadcast station is weak.	Refer to how to manually register a broadcast station. (Page 21)
Display says "Station not available".	Ensure that DAB coverage exists in your area.	Check that antenna is connected.
I can not access Secondary services.	At the time of publishing this manual not many Secondary services are available, this will increase as more DAB stations start broadcasting.	If a Secondary service station is available, the SECONDARY indicator will be displayed next to the station name.
I hear a burbling sound on some stations.	DAB like other digital media is good at producing quality audio from a low level signal, however if this signal, level is too low a "burbling" sound can sometimes be heard.	Use the unit's "Tuning aid" while repositioning your antenna to get the maximum signal strength and reduce this noise.

OPERATING EXTERNAL EQUIPMENT

Symptom	Possible Cause	Resolution
Audio from the external inputs (AUX1 to AUX3) is not emitted.	The connections to external devices are incorrect.	Refer to connecting external devices. (Page 9)
	The external device is not in play mode.	Be sure to play media according to the manual for the external device.
	The input source is incorrect.	Check the input source.
	The audio volume of the external device is low.	Increase the audio volume of the external device.
	The headphone jack has been mistaken for the AUX1 jack.	Check the connector being used for the connection.
Noise is being emitted from an external device.	The cable being used to connect to external is not connected securely.	Check cable connections.

NAMES AND FUNCTIONS

BASIC CONNECTIONS

BASIC OPERATIONS

BASIC SETTINGS

PRACTICAL CONNECTIONS

ADVANCED OPERATIONS

IF YOU EXPERIENCE PROBLEMS

MISCELLANEOUS

MISCELLANEOUS

SPECIFICATIONS AND EXTERNAL DIMENSIONS

CD PLAYER

Audio performance
S/N ratio (1kHz) 100dB or more
Dynamic range (1kHz) 100dB or more
Total harmonic distortion 0.01% or less

AUDIO AMP

Rated output (1kHz, total harmonic distortion 0.1%, 8Ω) 40W + 40W
Effective maximum output (1kHz, total harmonic distortion 10%, 8Ω) 50W + 50W
Input sensitivity/impedance
AUX1 110mV/24kΩ
AUX2, AUX3 200mV/32kΩ
Frequency response (5W, 8Ω)
AUX input 5Hz to 20kHz (±3dB)
Total harmonic distortion (1kHz, 5W, 8Ω)
AUX input 0.05%
S/N ratio (10W, 8Ω, IHF-A)
AUX input 86dB

TUNER

FM tuner
Range of receivable frequencies 87.5 to 108.0MHz
S/N ratio (mono) 65dB
Sensitivity (S/N 30dB) 6dBμV (IHF)
AM tuner
Range of receivable frequencies 522 to 1620kHz
S/N ratio 45dB
Sensitivity (S/N 20dB) 55dBμV/m

DAB TUNER SECTION

Frequency range
..... 174.928 (5A) ~ 239.200 (13F) MHz (BAND III)
Sensitivity -90 dBm
Signal-to-noise ratio 95 dB
THD+N 0.025 % (1 kHz)
Channel separation 70 dB (1 kHz)

POWER SUPPLY

Power supply voltage/frequency AC 230V, 50Hz
Power consumption 45W
Power consumption in standby mode 2.8W or less
Power consumption in low-power mode during standby (display panel off) 0.6W or less

MISCELLANEOUS

External dimensions (width x height x depth) . 280 x 111 x 302mm
Weight 4.2kg

Band III (174 to 240 MHz)

Frequency	Level	Frequency	Level
174.928 MHz	5A	208.064 MHz	9D
176.640 MHz	5B	209.936 MHz	10A
178.352 MHz	5C	211.648 MHz	10B
180.064 MHz	5D	213.360 MHz	10C
181.936 MHz	6A	215.072 MHz	10D
183.648 MHz	6B	216.928 MHz	11A
185.360 MHz	6C	218.640 MHz	11B
187.072 MHz	6D	220.352 MHz	11C
188.928 MHz	7A	222.064 MHz	11D
190.640 MHz	7B	223.936 MHz	12A
192.352 MHz	7C	225.648 MHz	12B
194.064 MHz	7D	227.360 MHz	12C
195.936 MHz	8A	229.072 MHz	12D
197.648 MHz	8B	230.784 MHz	13A
199.360 MHz	8C	232.496 MHz	13B
201.072 MHz	8D	234.208 MHz	13C
202.928 MHz	9A	235.776 MHz	13D
204.640 MHz	9B	237.488 MHz	13E
206.352 MHz	9C	239.200 MHz	13F

EXTERNAL DIMENSIONS (Units: mm)

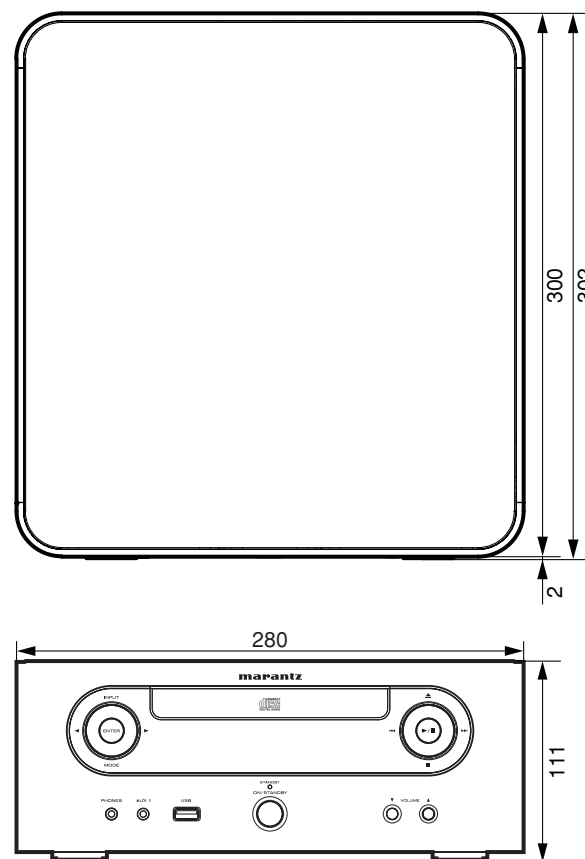

The specifications and external appearance of this unit may be changed without prior notification for the purpose of improvement.

CLASS 1 LASER PRODUCT
LUOKAN 1 LASERLAITE
KLASS 1 LASERAPPARAT

NOTES ABOUT THE DISCS

- HANDLE THE DISCS CAREFULLY SO AS NOT TO SCRATCH THEIR SURFACES.**
- KEEP THE SURFACES OF THE DISCS CLEAN AT ALL TIMES.**

When cleaning the surfaces of discs, always be sure to use the special cleaner and wipe the surfaces in the directions shown in the figure below.

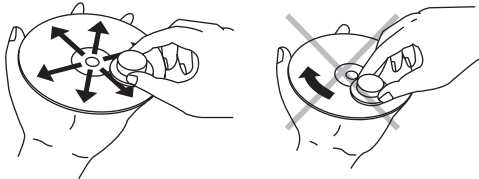

- Wipe the surface radially from the center.
- Do not wipe the surface in the circumferential direction.

DO NOT ATTACH PIECES OF PAPER OR STICKERS TO THE LABEL SURFACES OF THE DISCS.

When a disc has a piece of plastic tape or rental CD label with paste protruding from the edge or when a disc still bears traces of sticky tape or adhesive labels, do not attempt to play it. If such a disc is played on the CD player, you may find that you cannot remove it or that some other kind of malfunctioning may occur.

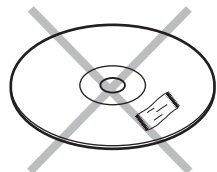

DO NOT USE DISCS WHICH COME IN SPECIAL SHAPES.

Do not attempt to play heart-shaped or octagonal discs or discs with any other special shapes. You may find that you cannot remove them or that some other kind of malfunctioning may occur in the player.

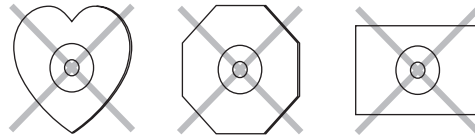

TO PROTECT YOUR DISCS FROM DAMAGE, AVOID PLACING THEM IN THE FOLLOWING LOCATIONS.

- Where they will be exposed to direct sunlight or where they will be close to a heater or other heat-radiating appliance
- Where the humidity level is high or it is very dusty
- Near a window or other such location where they may be exposed to rain

Get into the habit of putting the discs back in their cases after use.

DISCS THAT CAN BE PLAYED BACK

The following discs can be played using this CD receiver. Discs other than those listed below cannot be played.

Discs that can be played	Mark (logo)	Disc size
Music CDs		12 cm/8 cm discs
CD-R		12 cm/8 cm discs
CD-RW		12 cm/8 cm discs

Notes:

- Some CD-R/CD-RW discs may not be able to be played, depending on the recording mode used.
- Do not use an 8-cm adaptor for music CDs.

ABOUT PLAYING COPY-CONTROLLED CDS

Some copy-controlled CDs may not conform to official CD standards. They are special discs and may not play on the unit.

CLEANING OF EQUIPMENT EXTERNAL SURFACES

The exterior finish of your unit will last indefinitely with proper care and cleaning. Never use scouring pads, steel wool, scouring powders or harsh chemical agents (e.g., lye solution), alcohol, thinner, benzene, insecticide or other volatile substances as these will mar the finish of the equipment. Likewise, never use cloths containing chemical substances. If the equipment get dirty, wipe the external surfaces with a soft, lint-free cloth.

If the equipment becomes heavily soiled:

- dilute some washing up liquid in water, in a ratio of one part detergent to six parts water.
- dip a soft, lint free in the solution and wring the it is damp.
- wipe the equipment with the damp cloth.
- dry the equipment by wiping it with a dry cloth.



REPAIRS

Only the most competent and qualified service technicians should be allowed to service the factory-trained warranty station personnel have the knowledge and special facilities needed for repair and calibration of this precision equipment. After the warranty period has expired, repairs will be performed for a charge if the equipment can be returned to normal operation.

In the event of difficulty, refer to your dealer or write directly to the nearest location to you that is listed on the Marantz Authorized Service Station list. If writing, please include the model and serial number of the equipment together with a full description of what you think is abnormal about the equipment's behaviour.

www.marantz.com

You can find your nearest authorized distributor or dealer on our website.

marantz[®] is a registered trademark.

